

# GREELEY SADDLE CLUB

Showmanship - Age Groups 5 & Under, 6-9, & 10-13

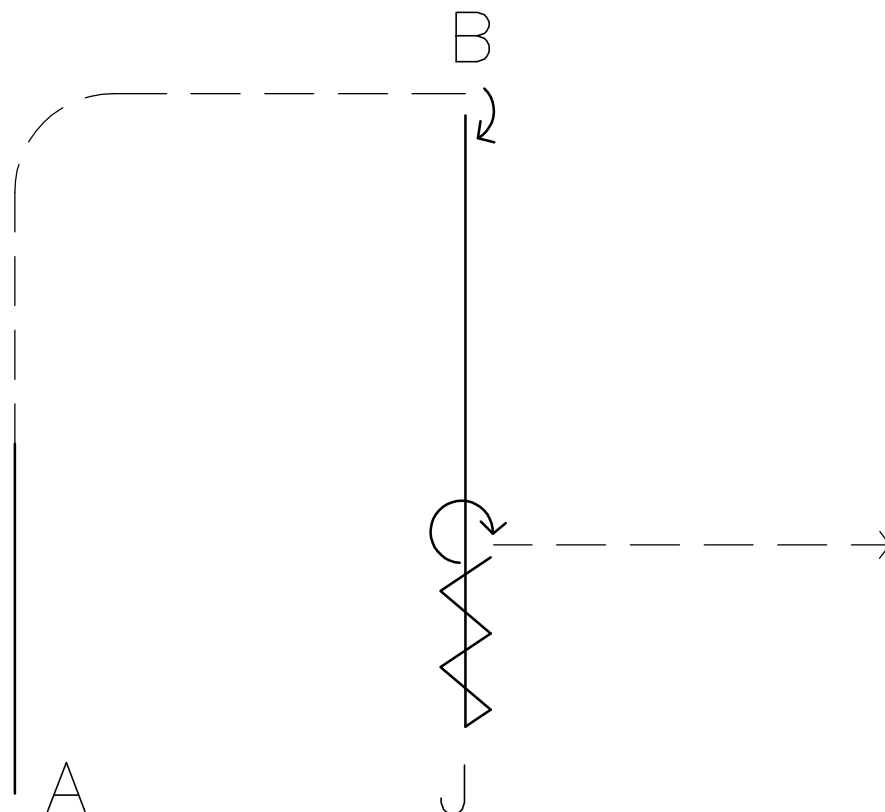

1. Start at A. Walk halfway to B.
2. Trot around corner to B. Stop at B.
3. Complete a 90° turn and walk to the Judge. Set up for inspection.
4. When dismissed, back 4 steps.
5. Complete a 270° turn. Trot to line up.

# GREELEY SADDLE CLUB

Showmanship - Age Groups 14-18, 19-39, 40 & Over

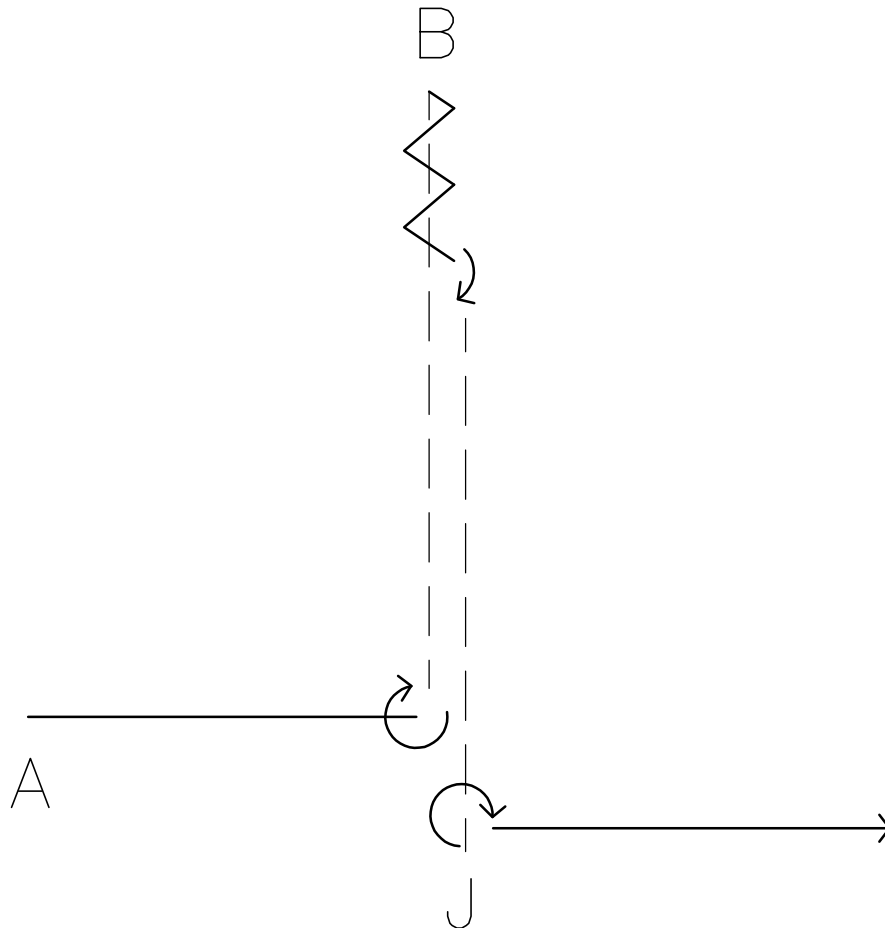

1. Start at A. Walk until aligned with B. Complete a 270° turn towards B.
2. Trot to B. Stop and and back 4 steps at B.
3. Complete a 180° turn and trot to the Judge. Set up for inspection.
4. When dismissed, complete a 270° turn.
5. Walk to line up.

# GREELEY SADDLE CLUB

## English Equitation - All Ages

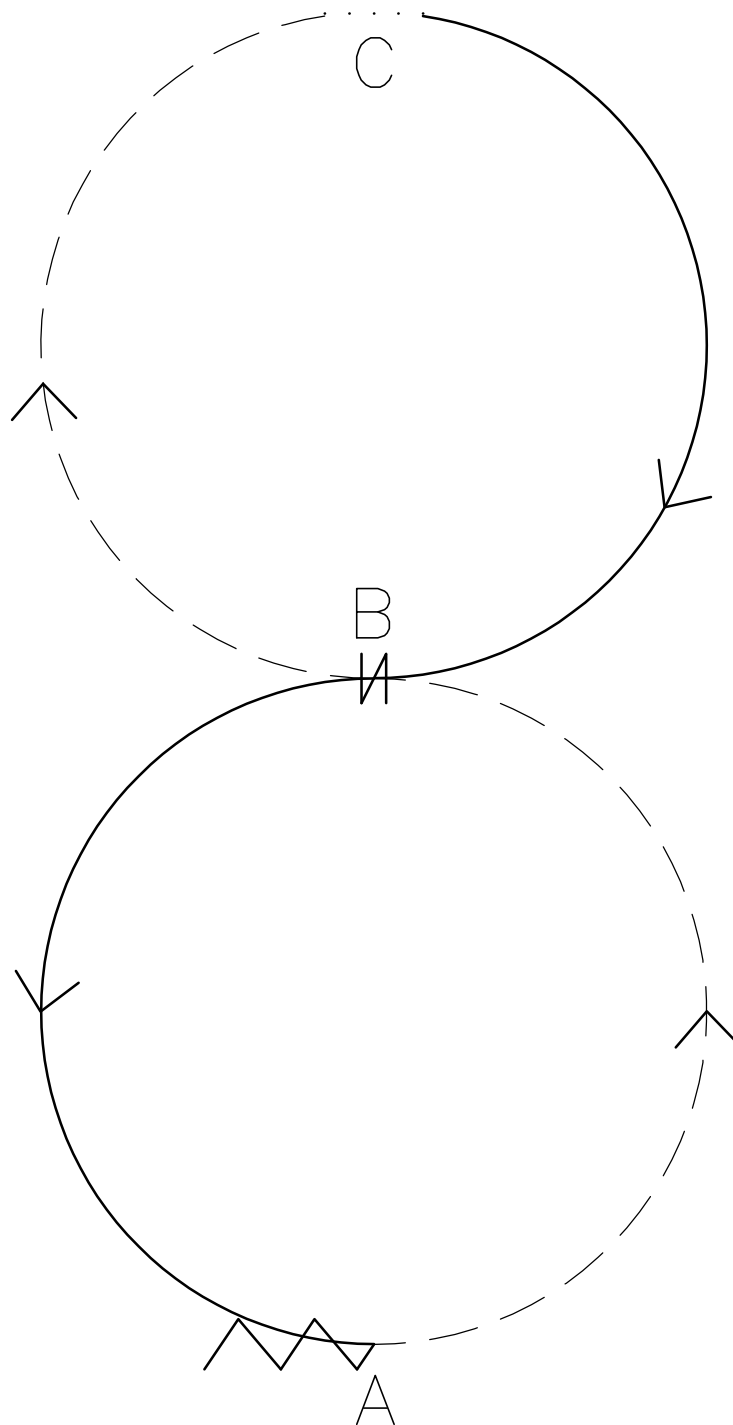

1. **Begin at A and trot a serpentine switching diagonals as appropriate.**
2. **Near C transition to a walk (3-4 steps) then up to a canter.**
3. **Canter serpentine with a simple lead change at B.**
4. **Halt at A and back one horse length.**

# GREELEY SADDLE CLUB

## Horsemanship - Age Groups 6-9 & 10-13

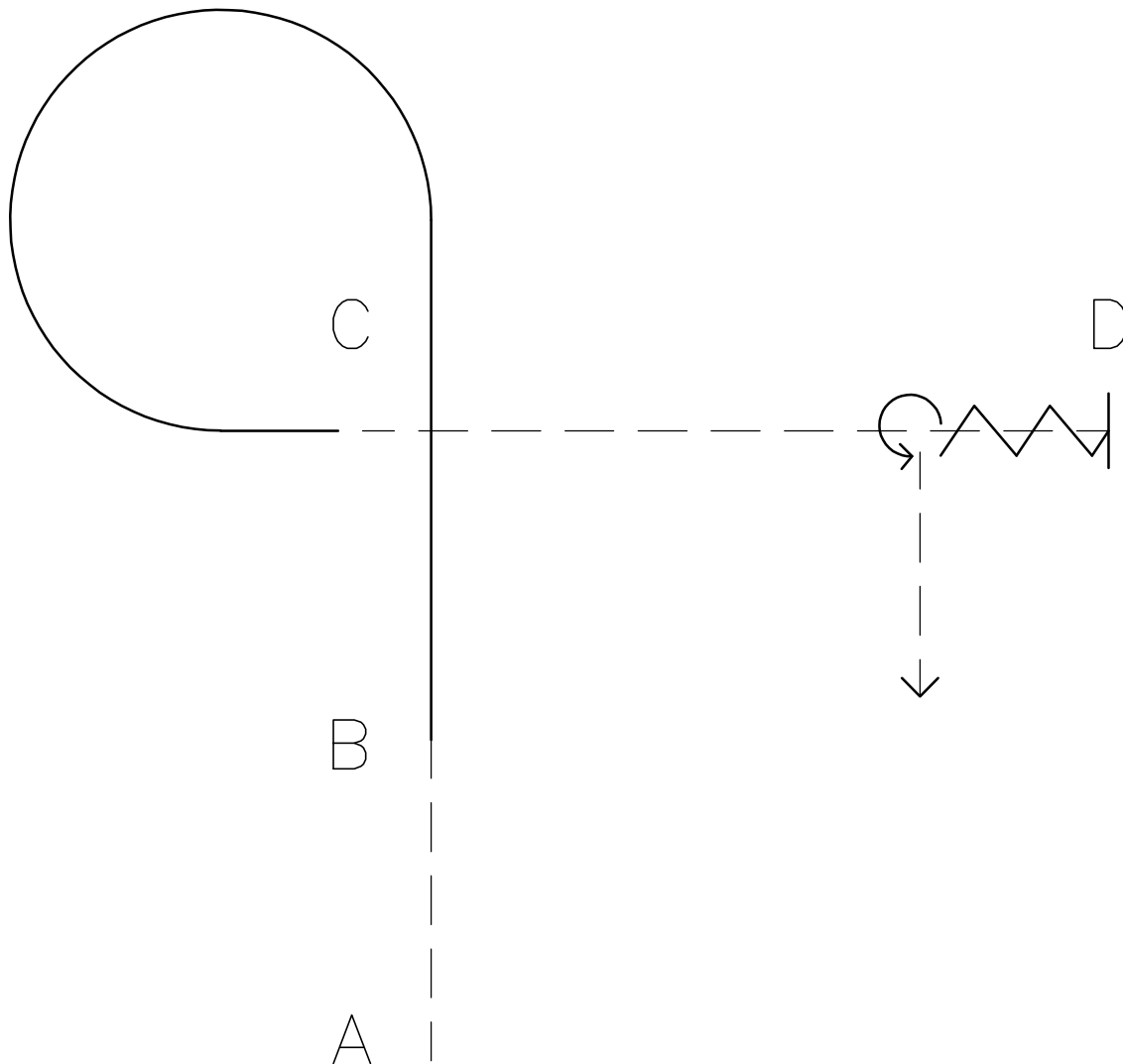

1. Jog from A to B.
2. Lope on the left lead from B to C. Continue on a circle around C as shown.
3. Trot from C to D.
4. Stop at D. Back 2 horse lengths.
5. Complete 270° turn to the left. Jog to line up.

# GREELEY SADDLE CLUB

Horsemanship - Age Groups 14-18, 19-39, 40 & Over

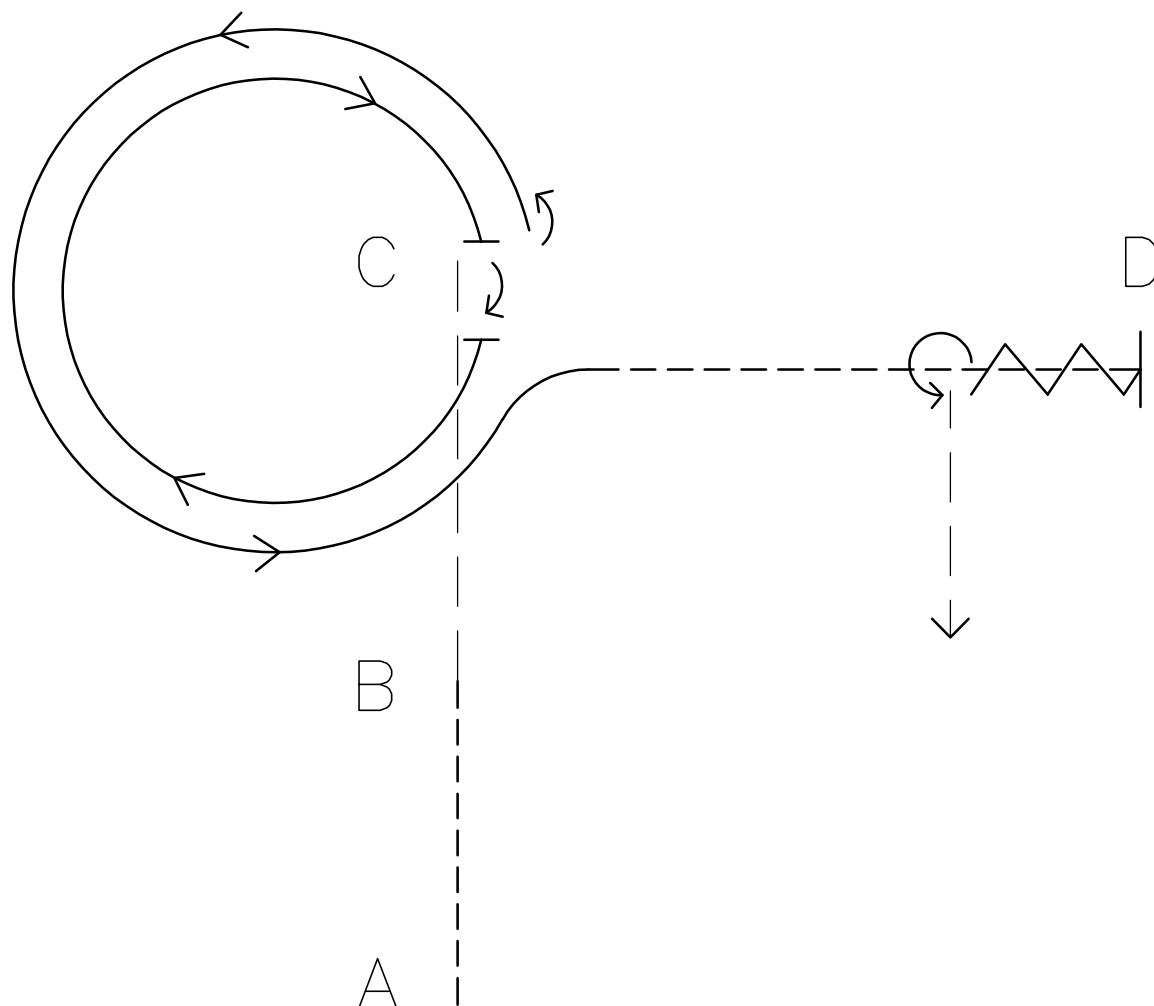

1. Jog from A to B.
2. Extended jog from B to C.
3. Stop at C. Complete a 180° turn to the right.
4. Lope a circle on the right lead around C. Stop when back at C.
5. Complete a 180° turn to the left. Lope a circle on the left lead around C.
6. Do not close the circle. Jog to D as shown.
7. Stop at D. Back 2 horse lengths.
8. Complete 270° turn to the left. Extended jog to line up.

# GREELEY SADDLE CLUB

## Reining - Age Group 6-9

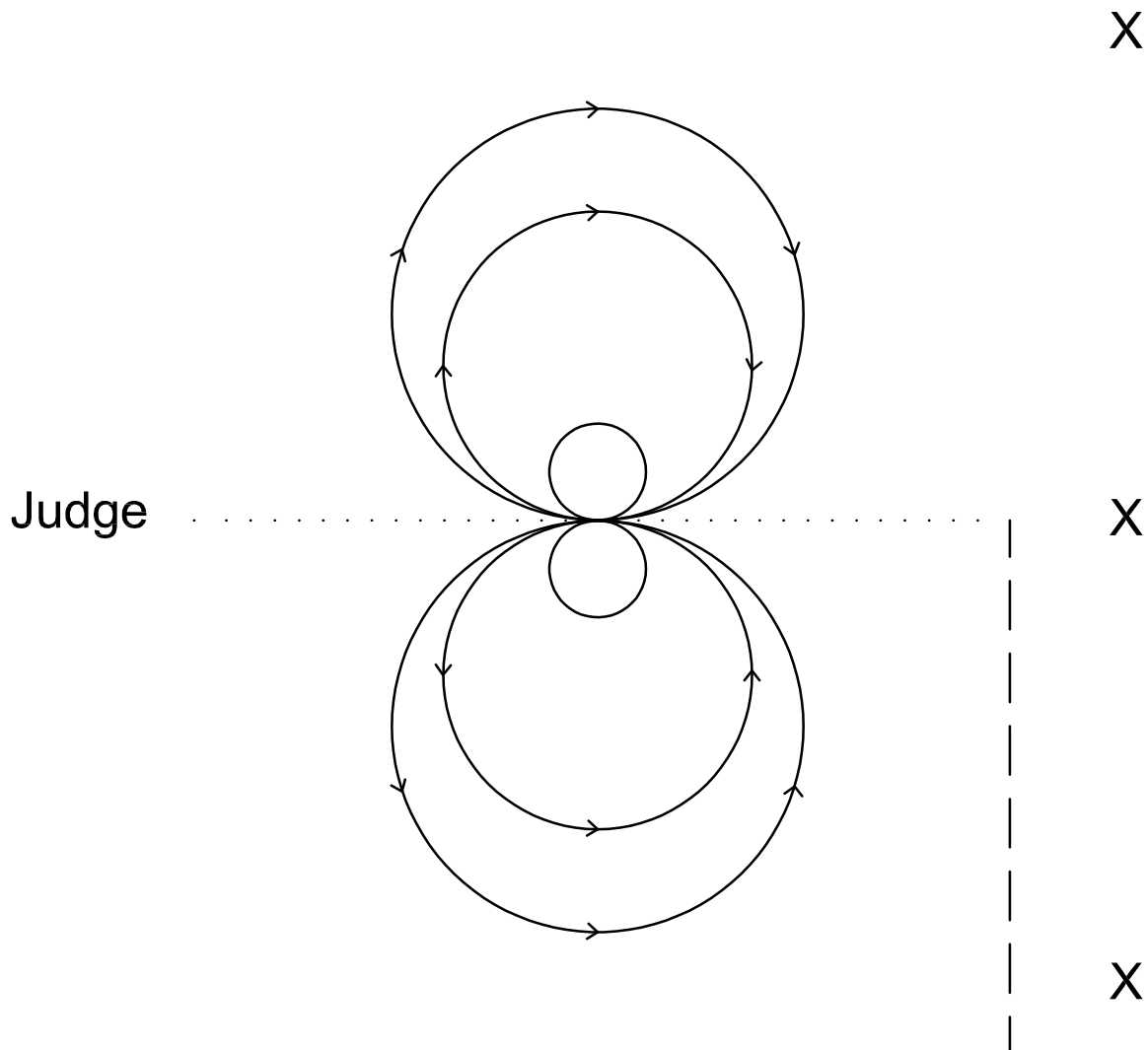

1. Trot in a straight line to the center marker, at least 20 feet from the rail.
2. Gradual stop through the walk.
3. Turn left, walk to center.
4. Lope two circles to the right with the first smaller and slower than the second.
5. At the center, stop and complete a 360° turn to the right.
6. Lope two circles to the left with the first smaller and slower than the second.
7. At the center, stop and complete a 360° turn to the left.
8. Walk to the judge for inspection.

# GREELEY SADDLE CLUB

Reining - Age Groups 10-13, 14-18, 19-39, & 40 & Over

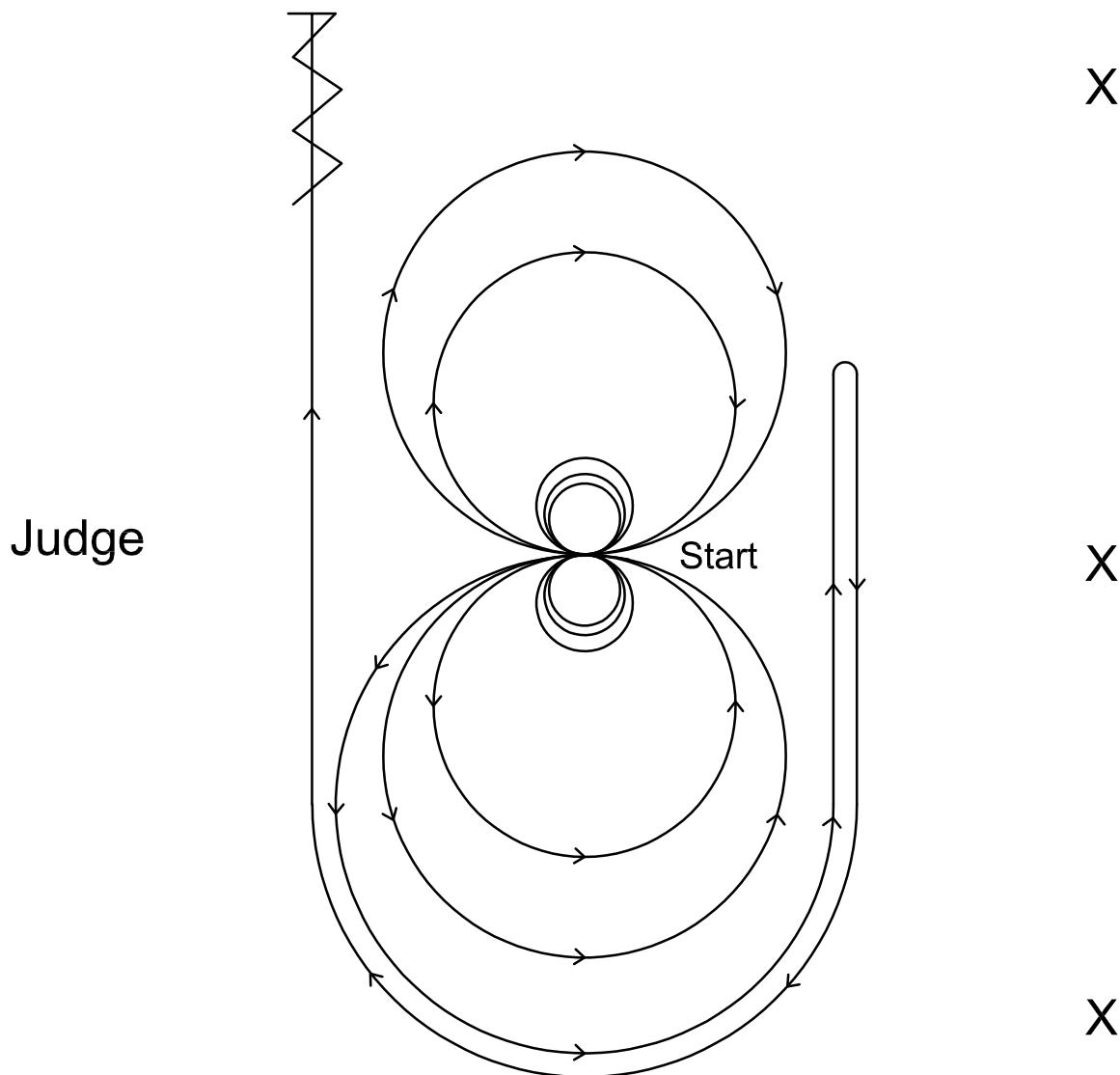

1. Jog to the center of the arena and face the judge on the left fence waiting to start your pattern.
2. Complete three spins to the right. Hesitate.
3. Complete three spins to the left. Hesitate.
4. Beginning on the right lead, complete two circles to the right. The first should be smaller and slower than the second. Change leads at the center.
5. Complete two circles to the left. The first being larger and faster and the second smaller and slower.
6. Begin a third circle to the left, but do not close it. Go around the end of the arena, run down the right side of the arena past the center marker, stop and roll back right.
7. Continue around the end of the arena to run down the left side of the arena past the end marker. Stop and back up.

# GREELEY SADDLE CLUB

## Trail - Age Groups 5 & Under, 6-9, & Novice

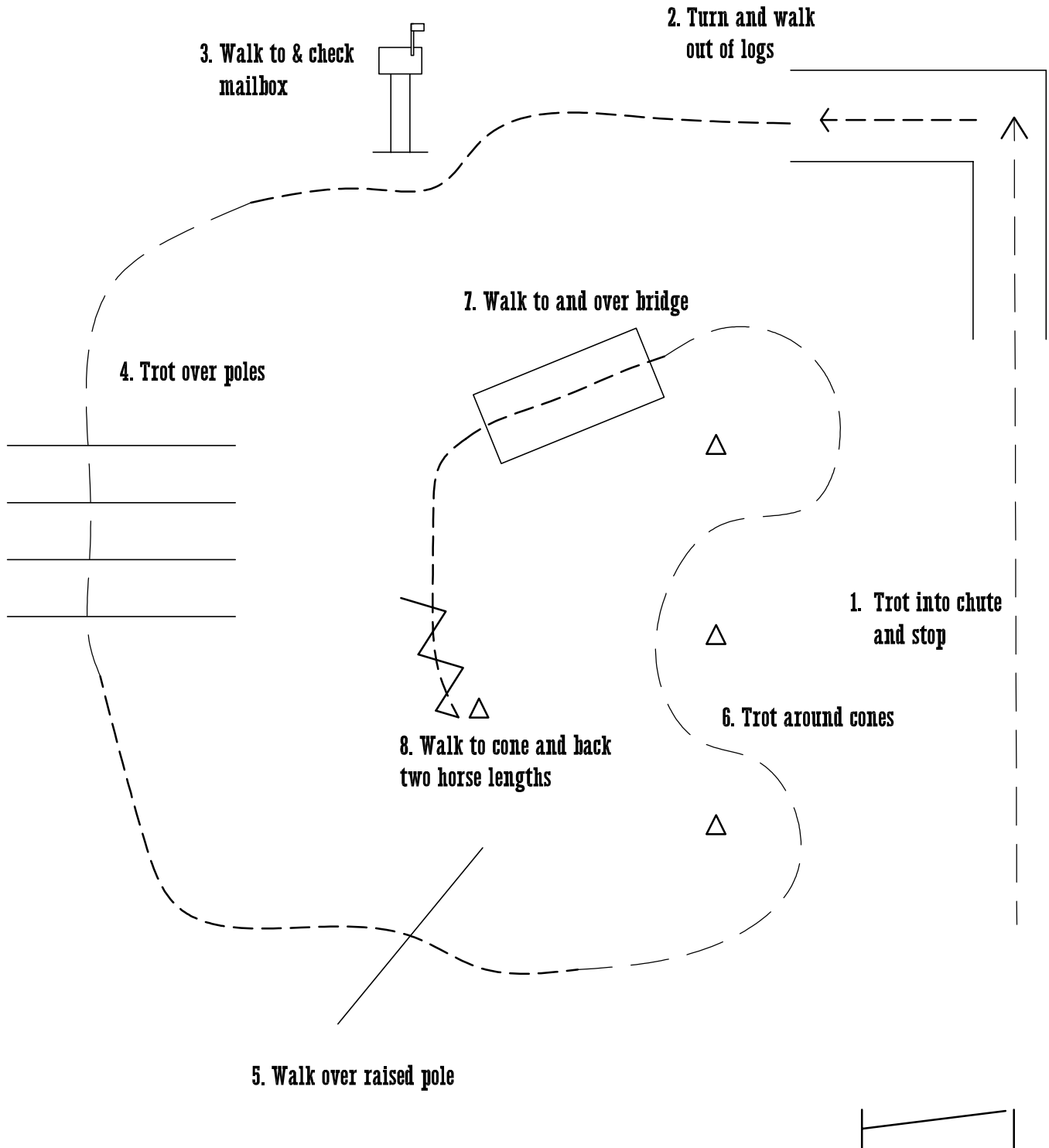



# GREELEY SADDLE CLUB

## Trail - Age Groups 10-13, 14-18, 19-39, 40 & Over

