

GREELEY SADDLE CLUB

Showmanship - Age Groups 5 & Under, 6-9, & 10-13

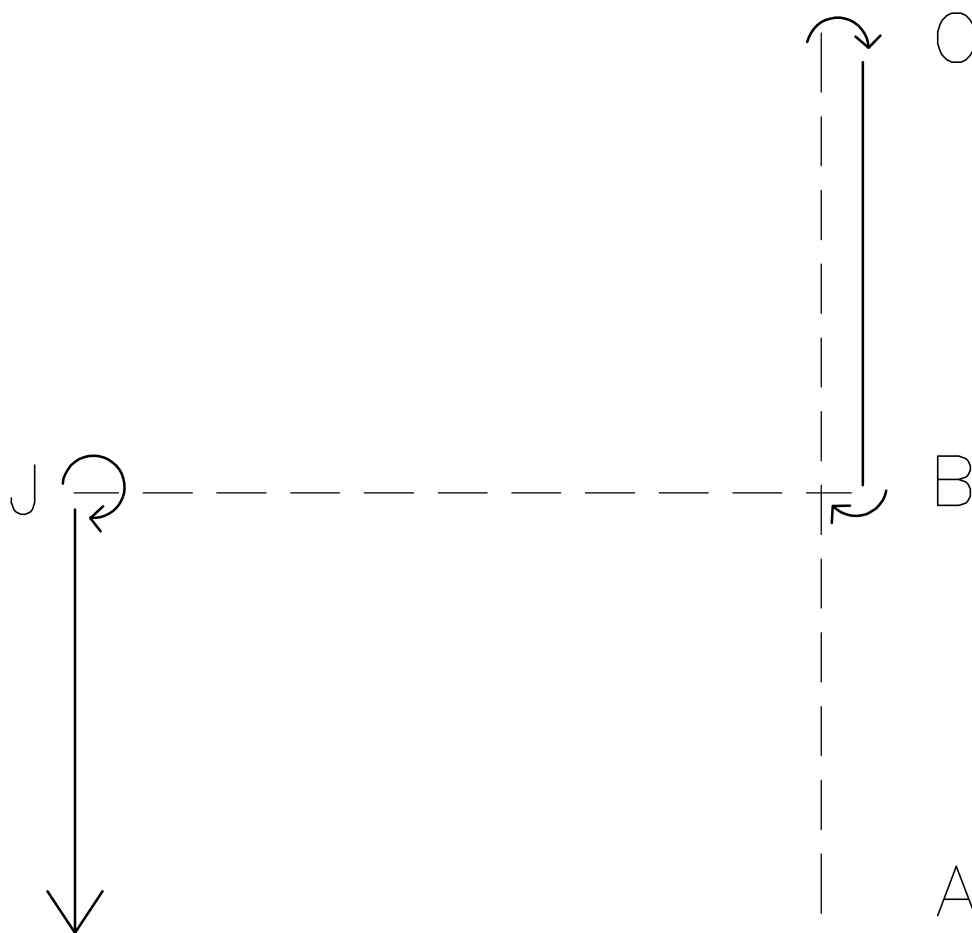

1. Start at A. Trot to C.
2. Stop at C. Complete a 180° turn. Walk to B.
3. At B, complete a 90° turn. Trot to the Judge.
4. When dismissed, complete a 270° turn and walk to line up.

GREELEY SADDLE CLUB

Showmanship - Age Groups 14-18, 19-39, 40 & Over

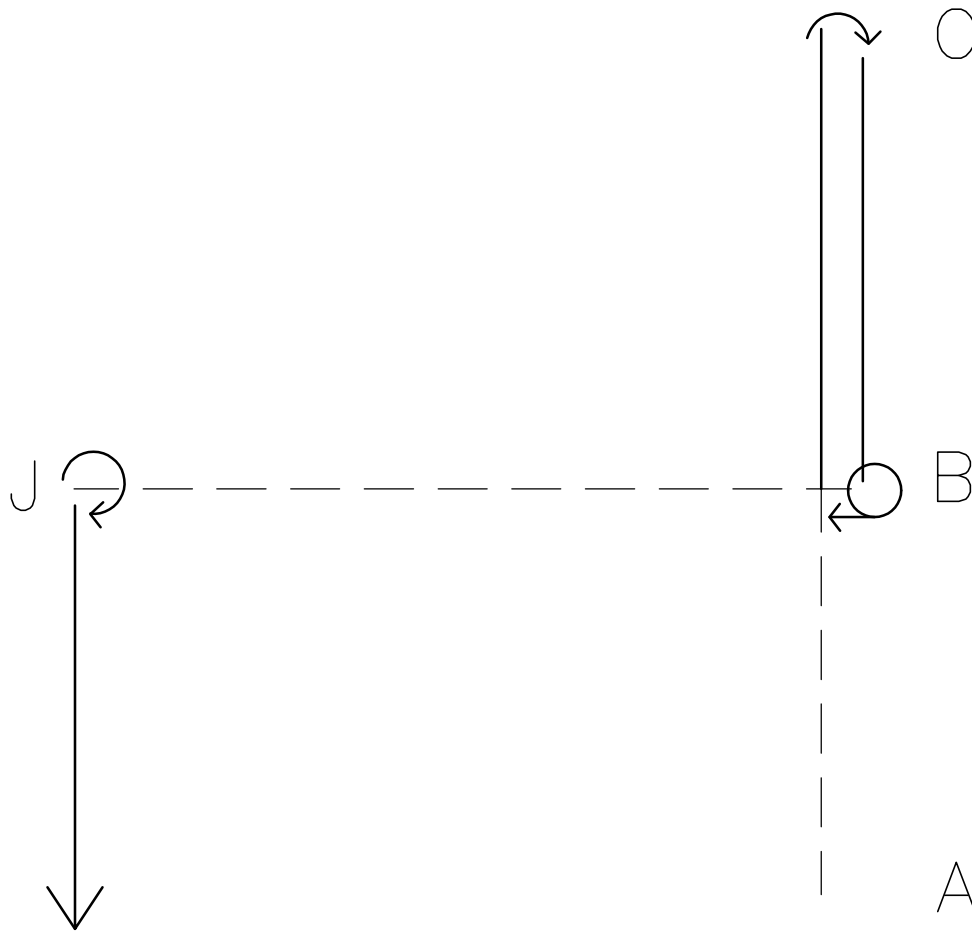

1. Start at A. Trot to B. Break to a walk from B to C.
2. At C, complete a 180° turn. Walk to B.
3. At B, stop and complete a 450° turn. Trot to the Judge.
4. When dismissed, complete a 270° turn and walk to line up.

GREELEY SADDLE CLUB

English Equitation - All Ages

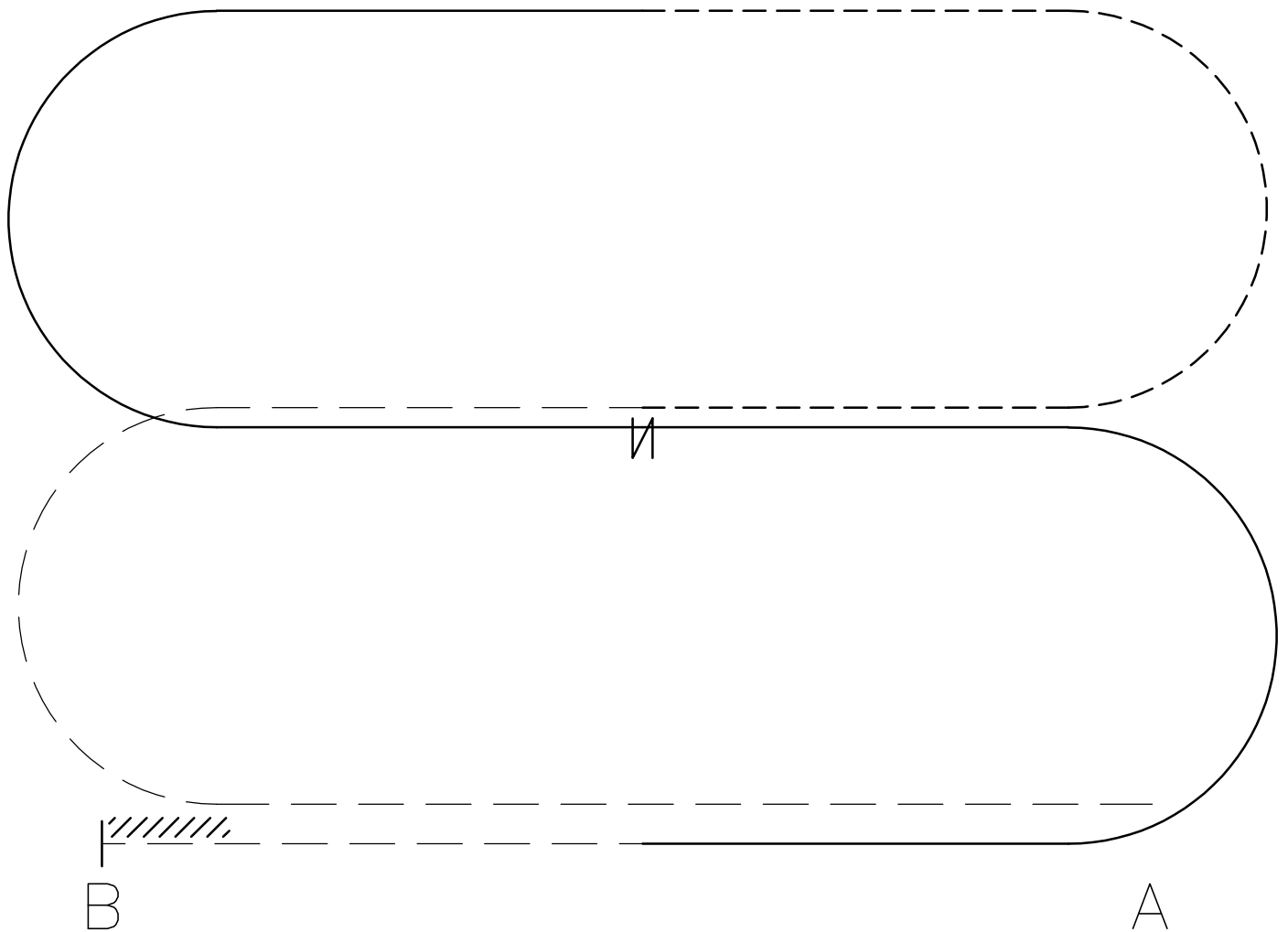

1. Start at A and trot on the left diagonal to B and around as shown.
2. Sitting trot midway between B and A to complete serpentine.
3. Pick up the left lead canter and continue around as shown.
4. Change leads back at the midway point and canter on the right lead to complete serpentine.
5. Posting trot on the right diagonal from the midway point back to B.
6. Stop at B. Back 2 horse lengths.

GREELEY SADDLE CLUB

Horsemanship - Age Groups 6-9 & 10-13

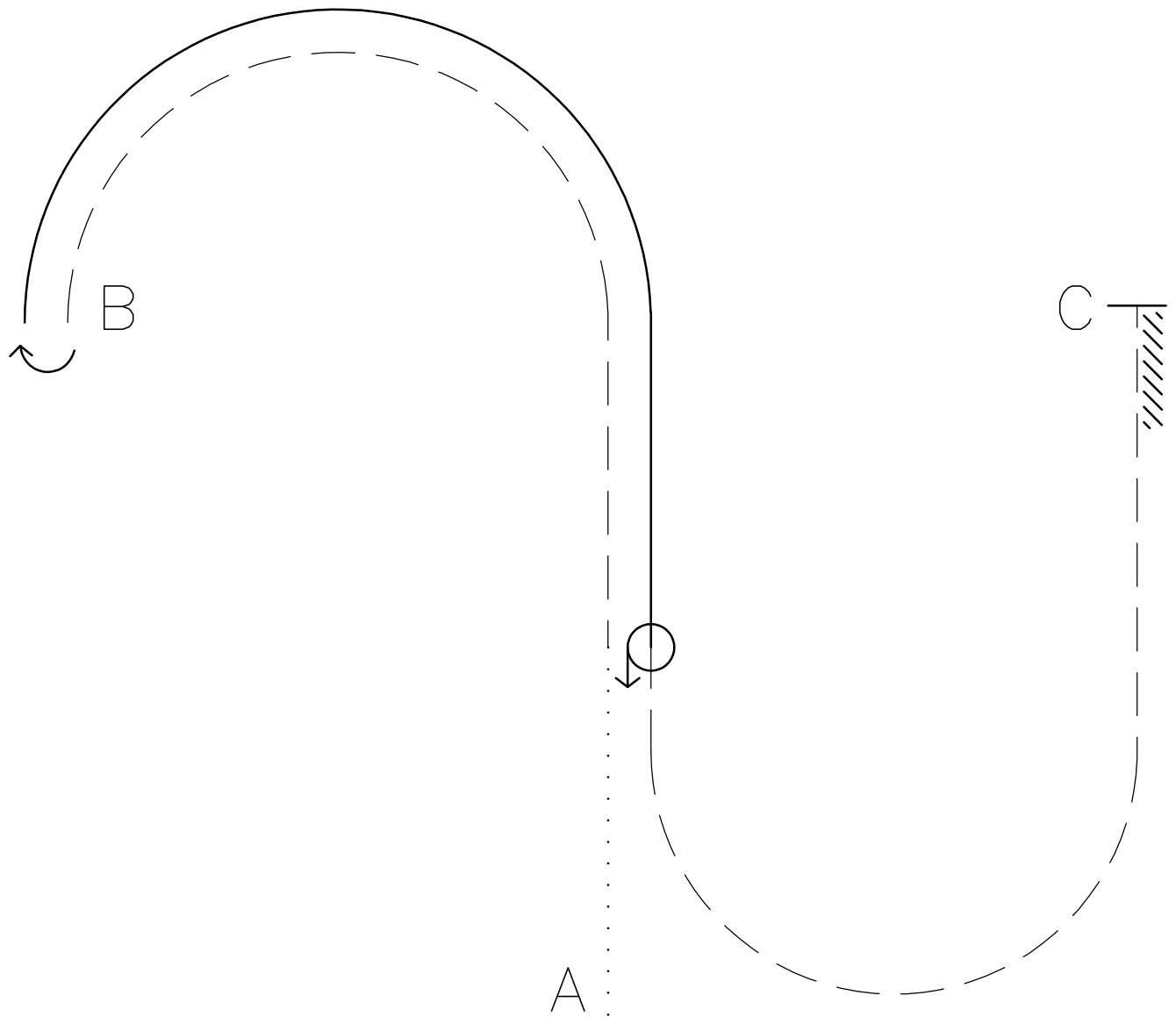

1. Walk straight from A. Jog straight and around to B as shown.
2. Stop at B. Complete a 180 turn to the right.
3. Lope on the right lead around and towards A.
4. Stop before A. Complete a 360 turn to the left.
5. Jog around to C as shown.
6. Stop at C. Back one horse length.

GREELEY SADDLE CLUB

Horsemanship - Age Groups 14-18, 19-39, 40 & Over

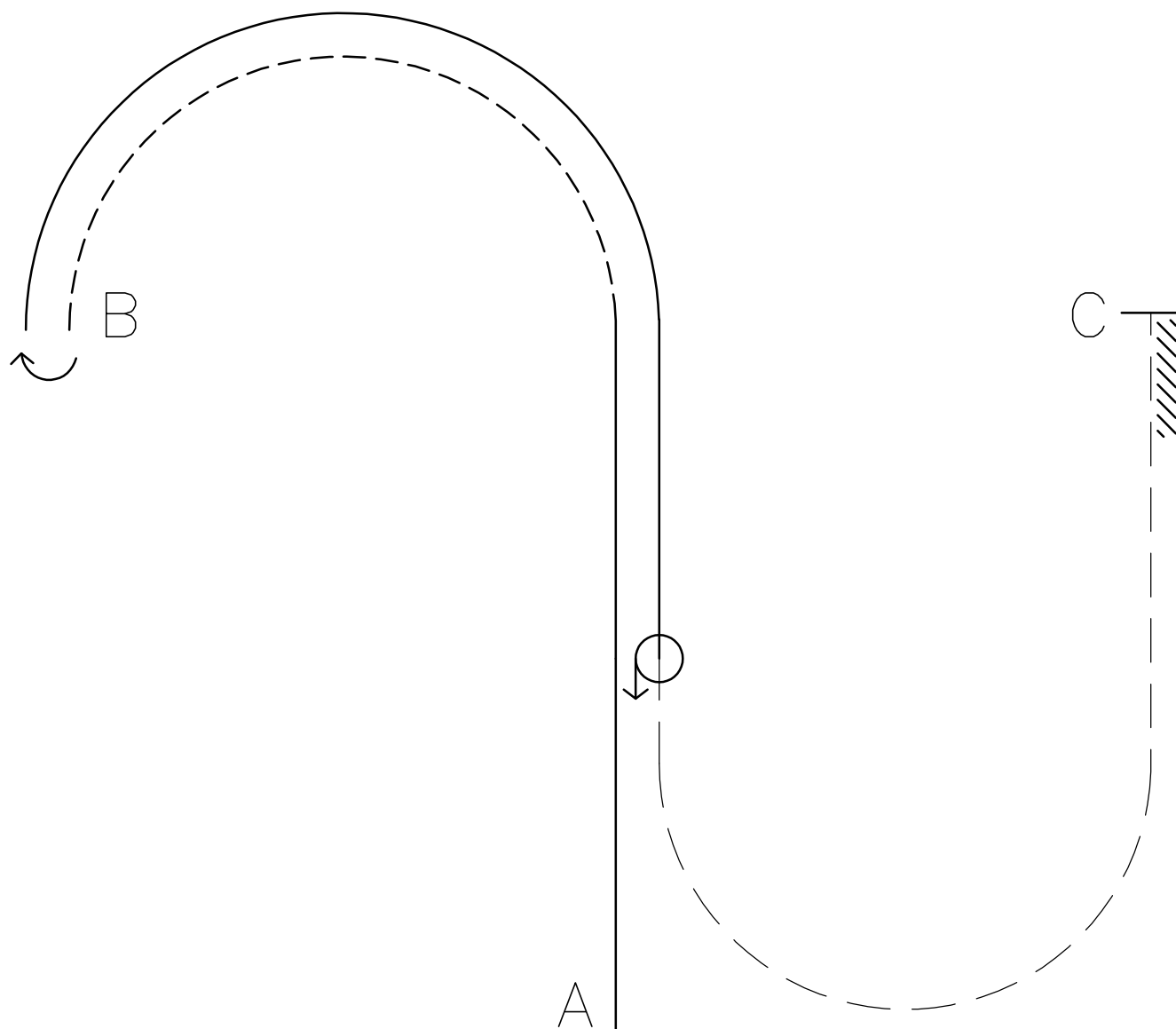

1. Lope on the left lead straight from A.
2. Break to a jog when even with B and jog around to B.
3. Stop at B. Complete a 180 turn to the right.
4. Lope on the right lead around and towards A.
5. Stop before A. Complete a 360 turn to the left.
6. Extended jog around to C as shown.
7. Stop at C. Back one horse length.

GREELEY SADDLE CLUB

Reining - Age Group 6-9

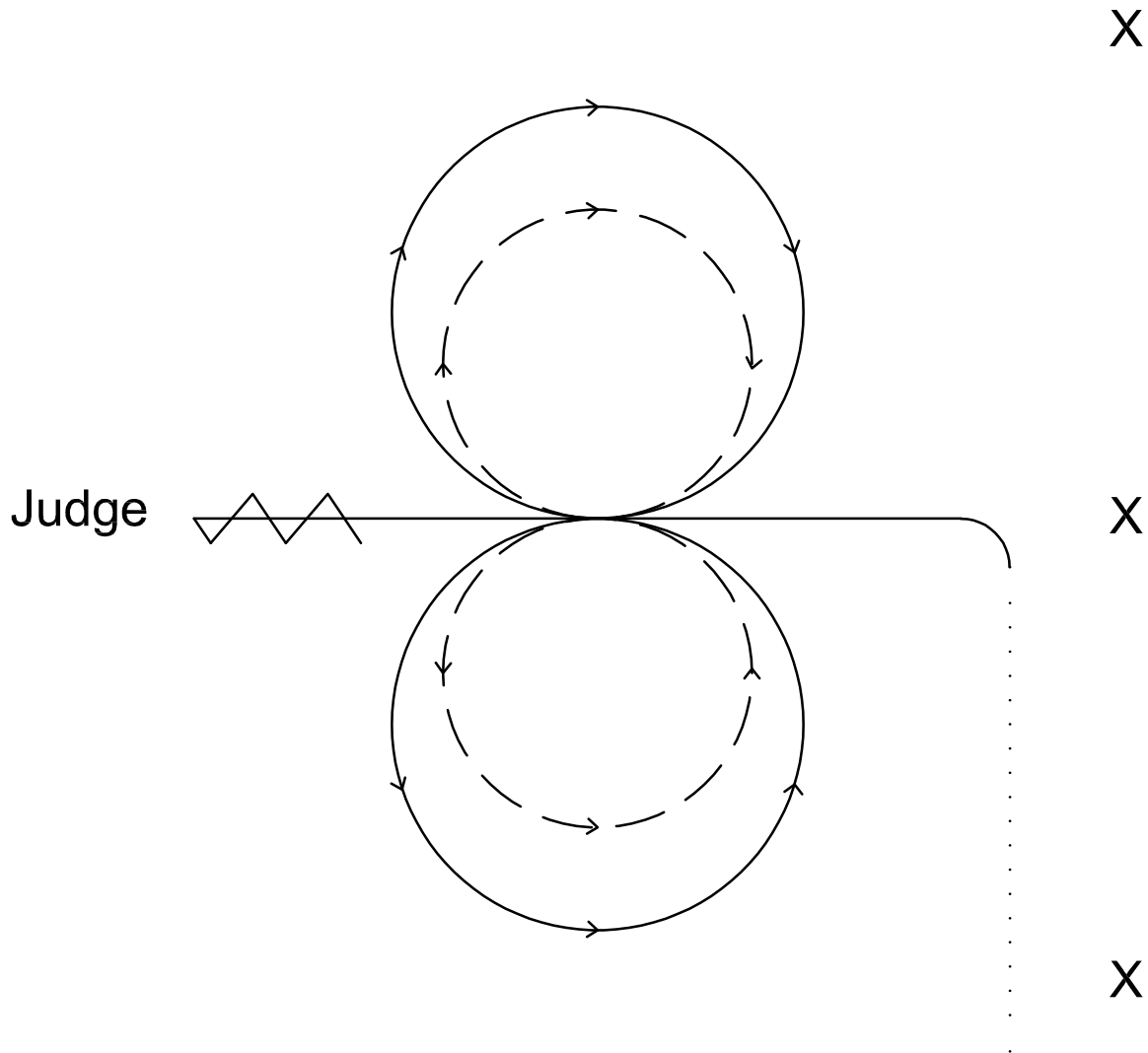

1. Walk to the center marker 20 feet from the fence.
2. Left lead to center.
3. Lope large figure 8 at moderate speed. Left circle first with a simple change at the center.
4. Jog a small figure 8 with a circle to the left first.
5. At the center, pick up the right lead. Lope straight for 10 feet.
6. Stop.
7. Back.
8. Walk to the judge for inspection.

GREELEY SADDLE CLUB

Reining - Age Groups 10-13, 14-18, 19-39, 40 & Over

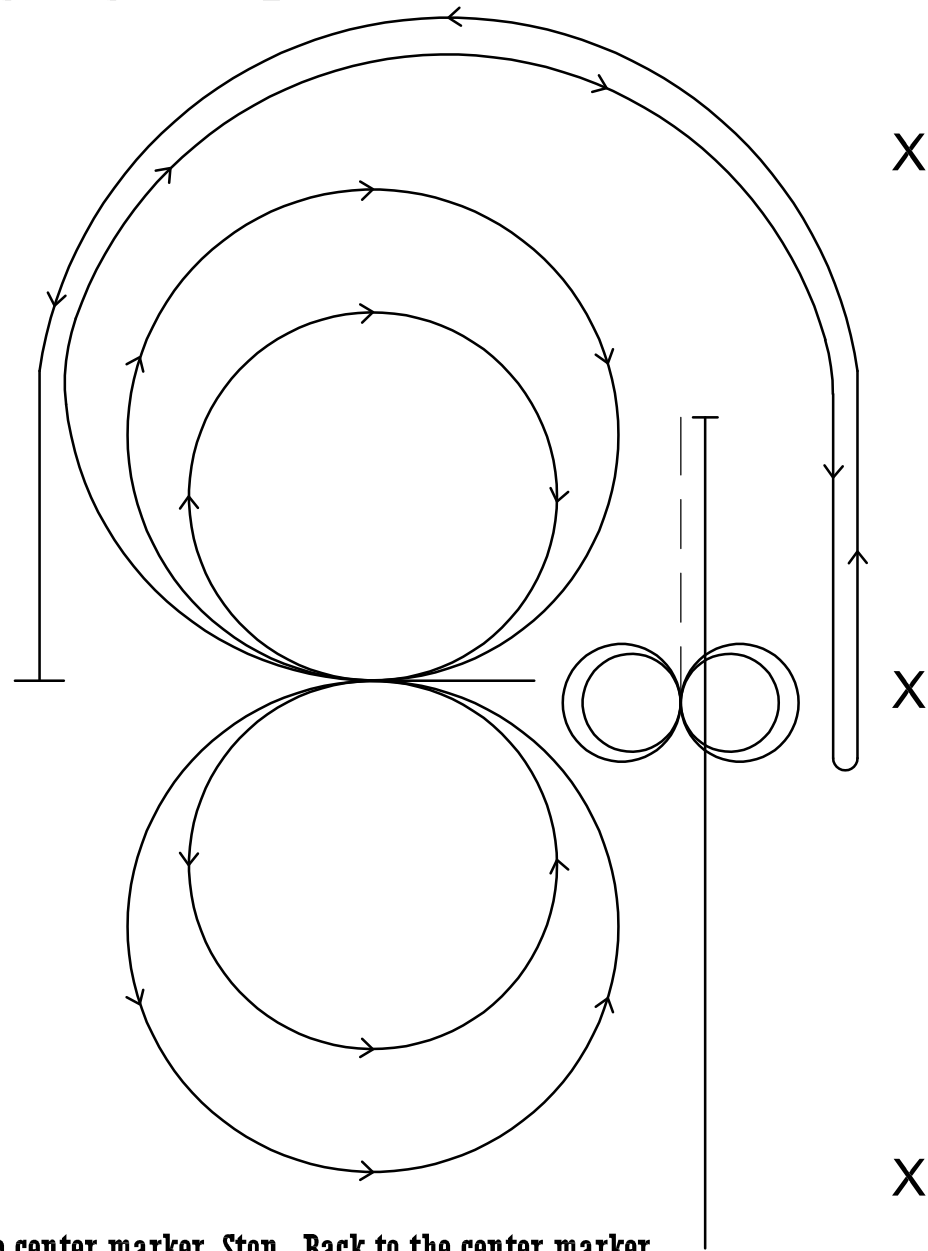

1. Run down past the center marker. Stop. Back to the center marker.
2. Complete two spins to the right.
3. Complete two and a quarter spins to the left.
4. Run two circles to the right with the first being smaller and slower and the second larger and faster.
5. Change leads at the center and complete two circles to the left the first smaller and slower and the second larger and faster.
6. Change leads at the center and start a circle to right, but do not close it. Run past the center marker and complete a rollback towards the fence.
7. Run back around the arena past the center marker and complete stop. Hesitate to show pattern completion.

GREELEY SADDLE CLUB

Trail - Age Groups 5 & Under, 6-9, & Novice

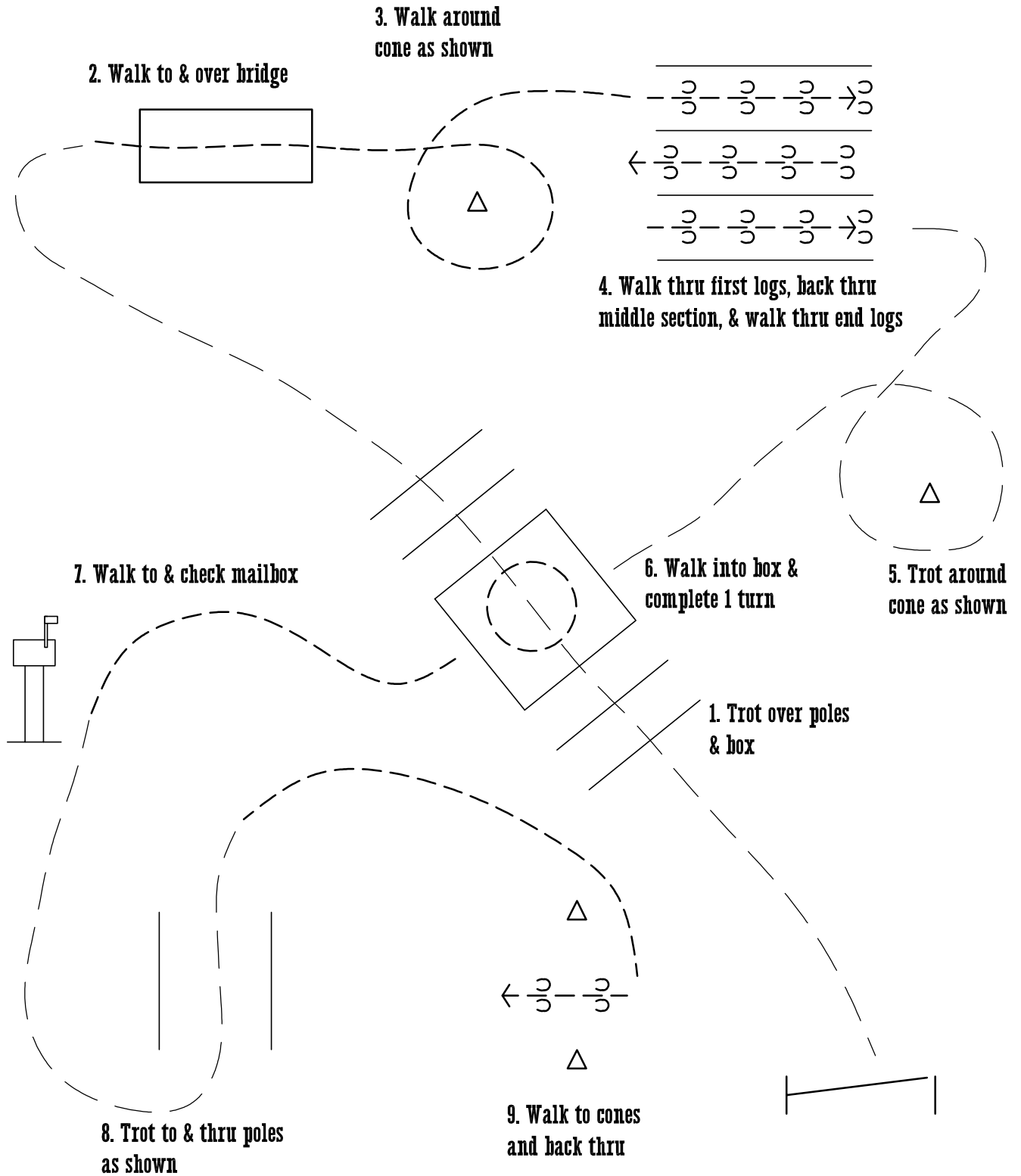

GREELEY SADDLE CLUB

Trail - Age Groups 10-13, 14-18, 19-39, 40 & Over

