

GREELEY SADDLE CLUB

English Equitation - All Ages

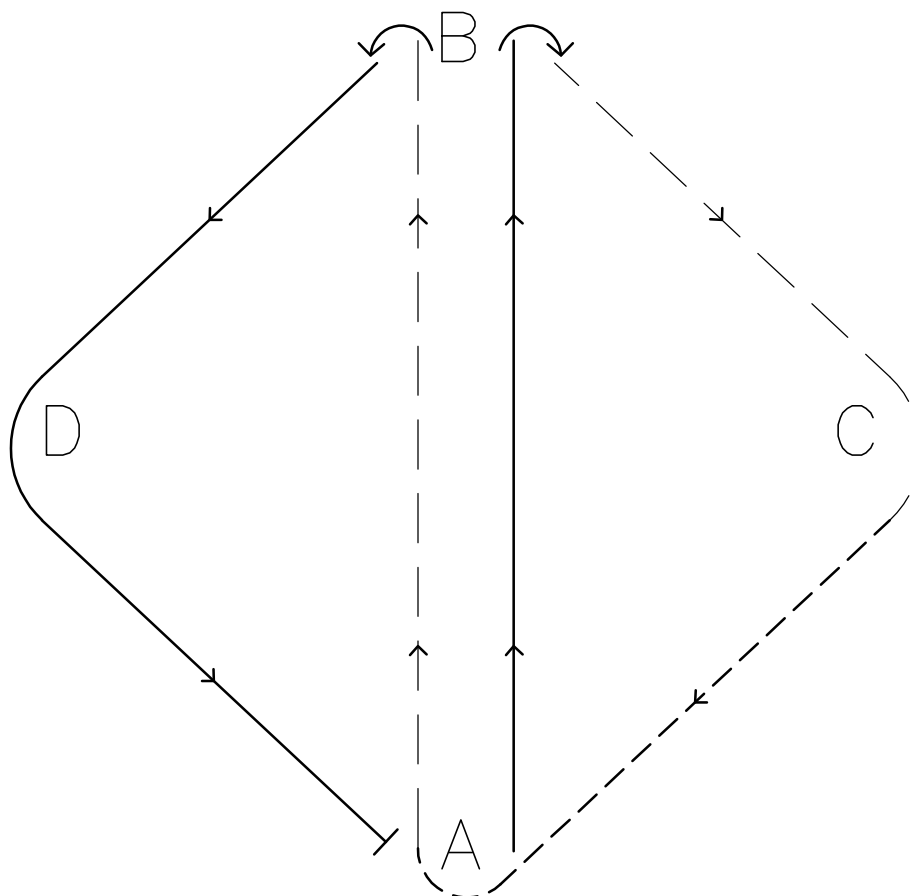

1. Start at A. Canter on the right lead to B.
2. Stop at B and complete a forehand turn to the right toward C.
3. Posting trot on the left diagonal to and around C.
4. Sitting trot from C to and around A.
5. At A, posting trot on the right diagonal back to B.
6. Stop at B and complete a hindquarter pivot to the left toward D.
7. Canter on the left lead to and around D toward A. Stop at A.

GREELEY SADDLE CLUB

Showmanship - Age Groups 5 & Under, 6-9, & 10-13

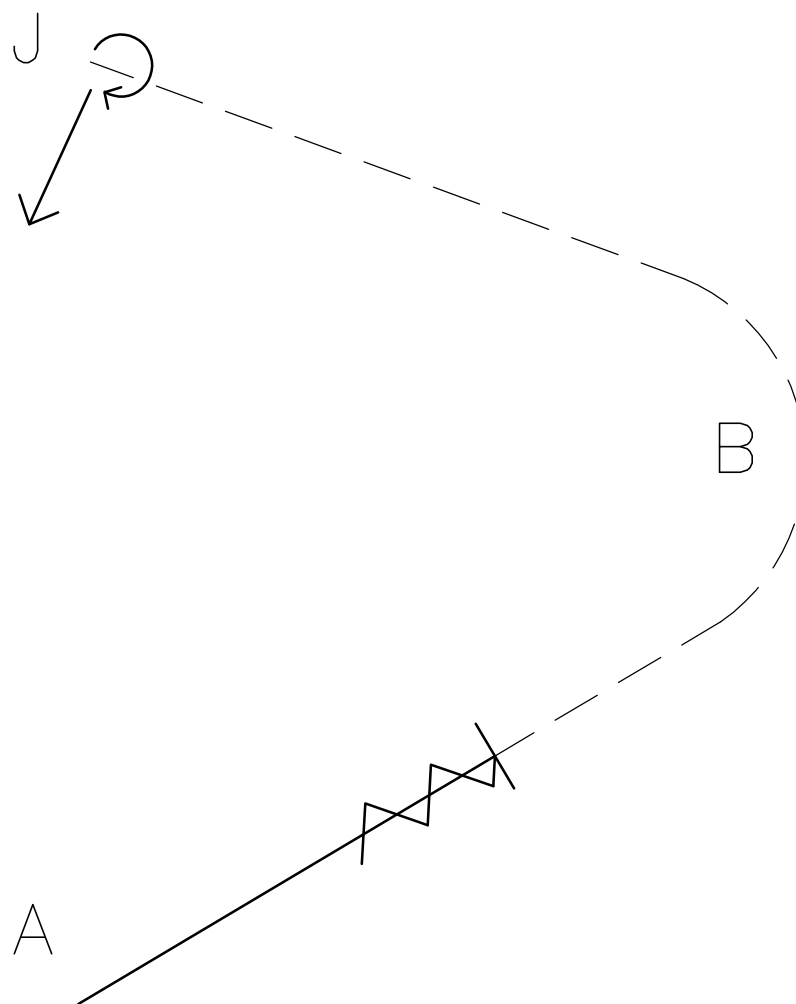

1. Start at A.
2. Walk halfway to B. Stop and back 5 steps.
3. Trot to and around B.
4. Continue on to the Judge. Set up for inspection.
5. When dismissed, complete a 270° turn and walk to line up.

GREELEY SADDLE CLUB

Showmanship - Age Groups 14-18, 19-39, 40 & Over

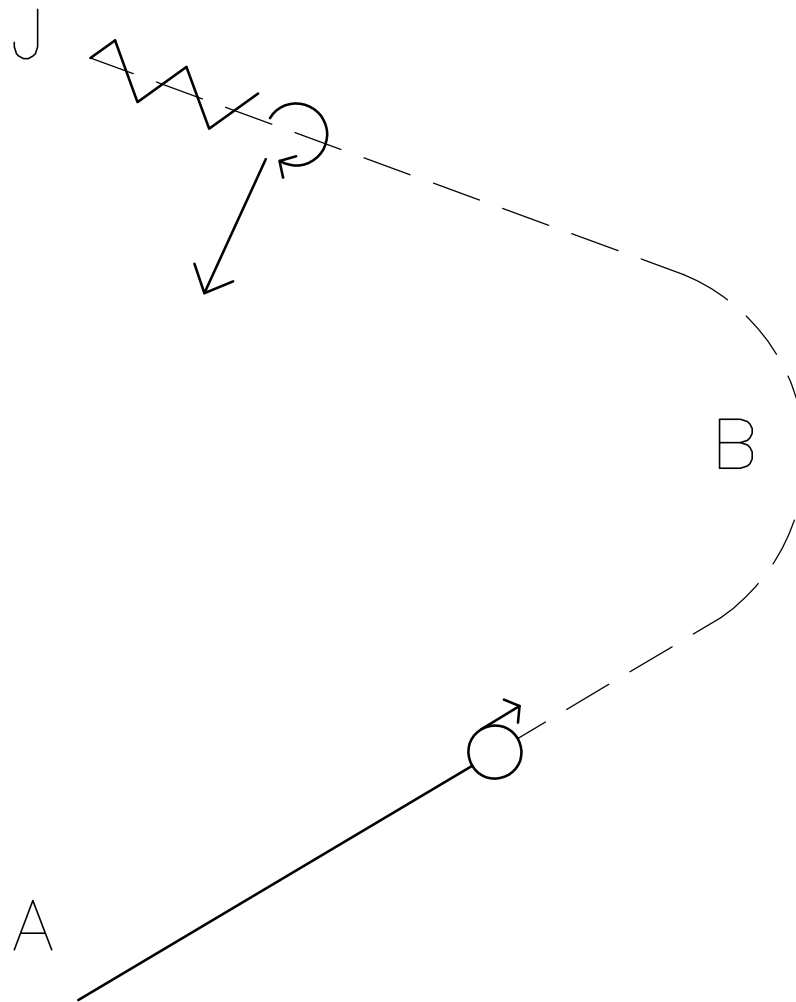

1. Start at A.
2. Walk halfway to B and stop. Execute a 360° turn.
3. Trot to and around B, continue on to the Judge.
4. Set up for inspection.
5. When dismissed, back 6 steps and then complete a 270° turn. Walk to line up.

GREELEY SADDLE CLUB

Horsemanship - Age Groups 6-9 & 10-13

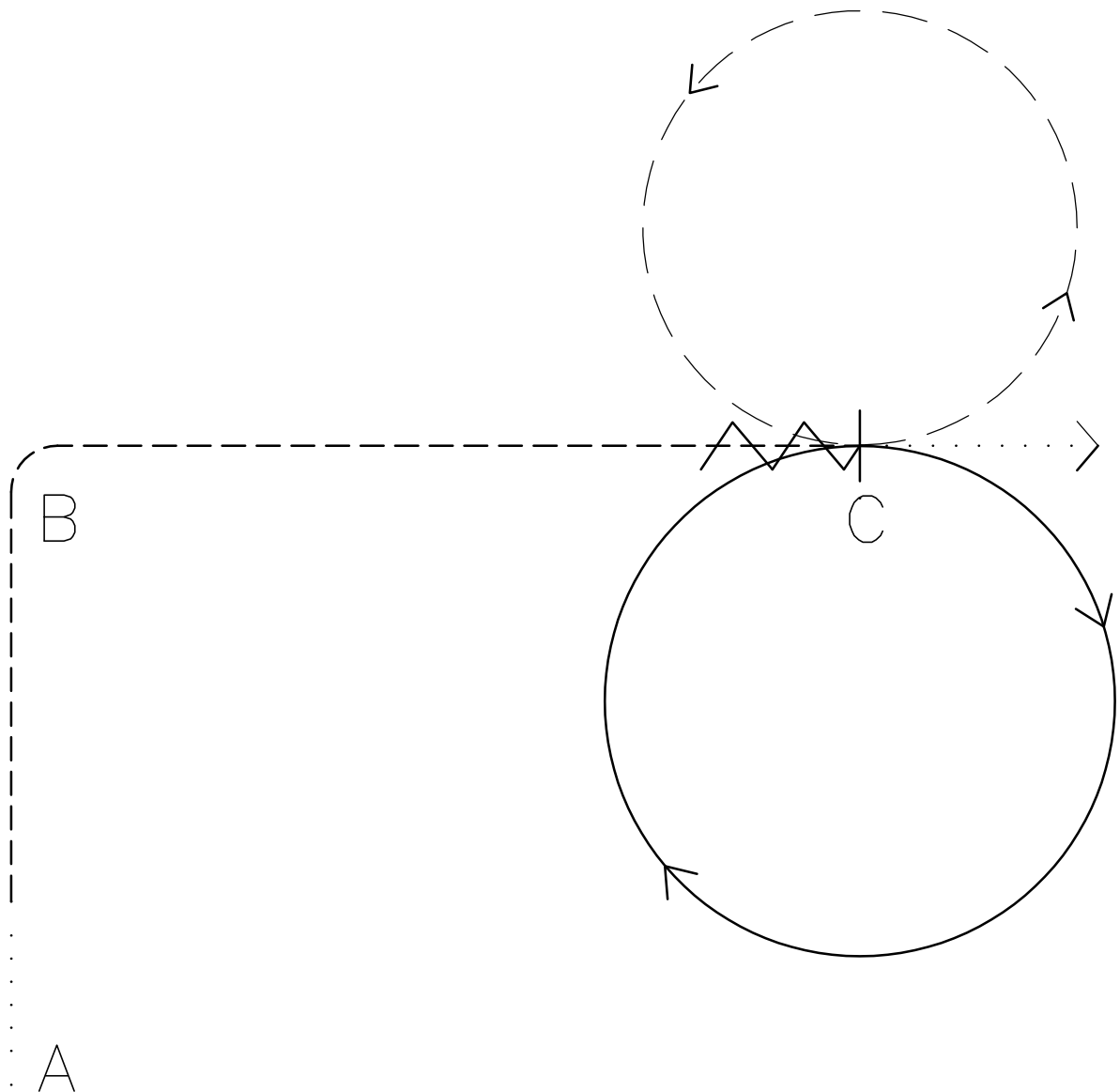

1. Walk approximately two horse lengths from A.
2. Jog to B and a square corner around B. Continue at a jog to C.
3. At C, lope a circle to the right on the right lead.
4. Stop at C. Back 4 steps.
5. Complete a circle to the left at an extended jog.
6. When circle is completed, break to a walk and return to line up.

GREELEY SADDLE CLUB

Horsemanship - Age Groups 14-18, 19-39, 40 & Over

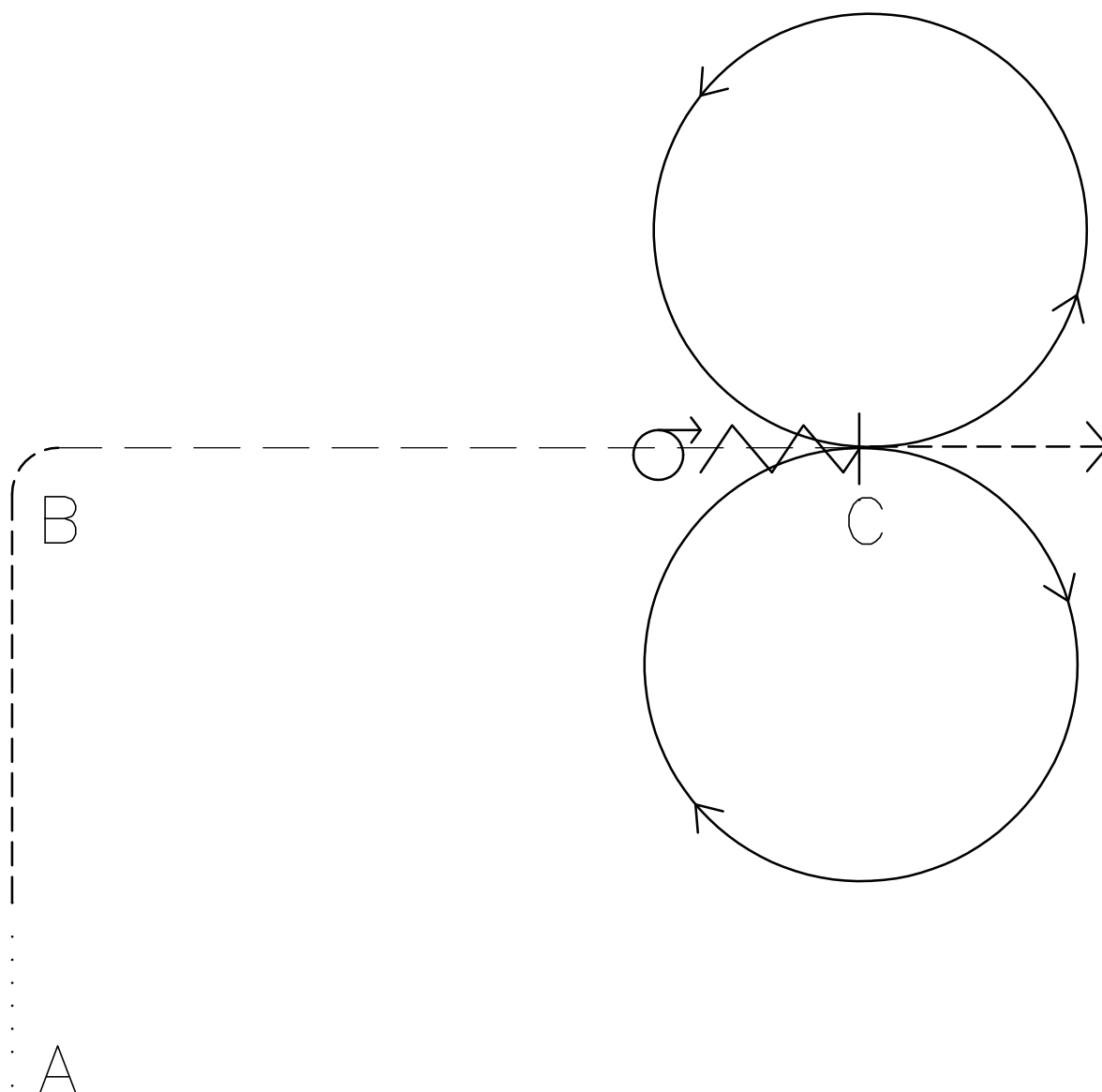

1. Walk approximately two horse lengths from A.
2. Jog to B and a square corner around B. Extended jog to C.
3. At C, lope a circle to the right on the right lead as shown.
4. Stop at C and back 4 steps then execute a 360° pivot to the left.
5. Lope a circle to the left on the left lead as shown.
6. When circle is completed, break to a jog and return to line up.

GREELEY SADDLE CLUB

Reining - Age Groups 6-9

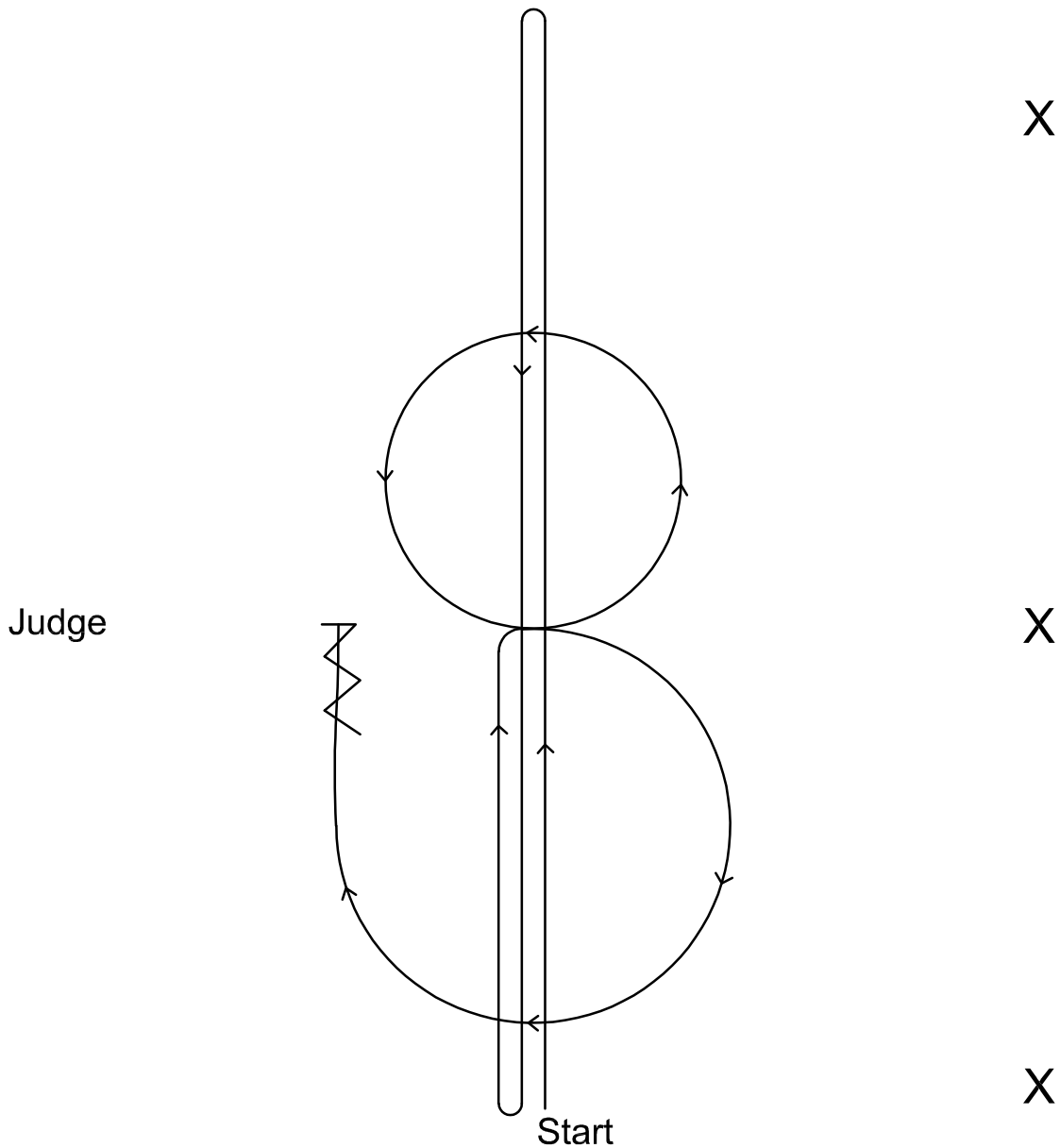

1. Run down past the end marker. Stop. Roll back to the left.
2. Run down past the other end marker. Stop. Roll back to the right.
3. Run to the center and stop.
4. Complete a 1/4 turn to the right.
5. Ride a small slow circle to the left.
6. Change leads at the center and ride a larger faster circle to the right.
7. Don't fully close circle and stop at center marker as shown.
8. Back. Hesitate. Ride to judge for inspection.

GREELEY SADDLE CLUB

Reining - Age Groups 10-13, 14-18, 19-39, 40 & Over

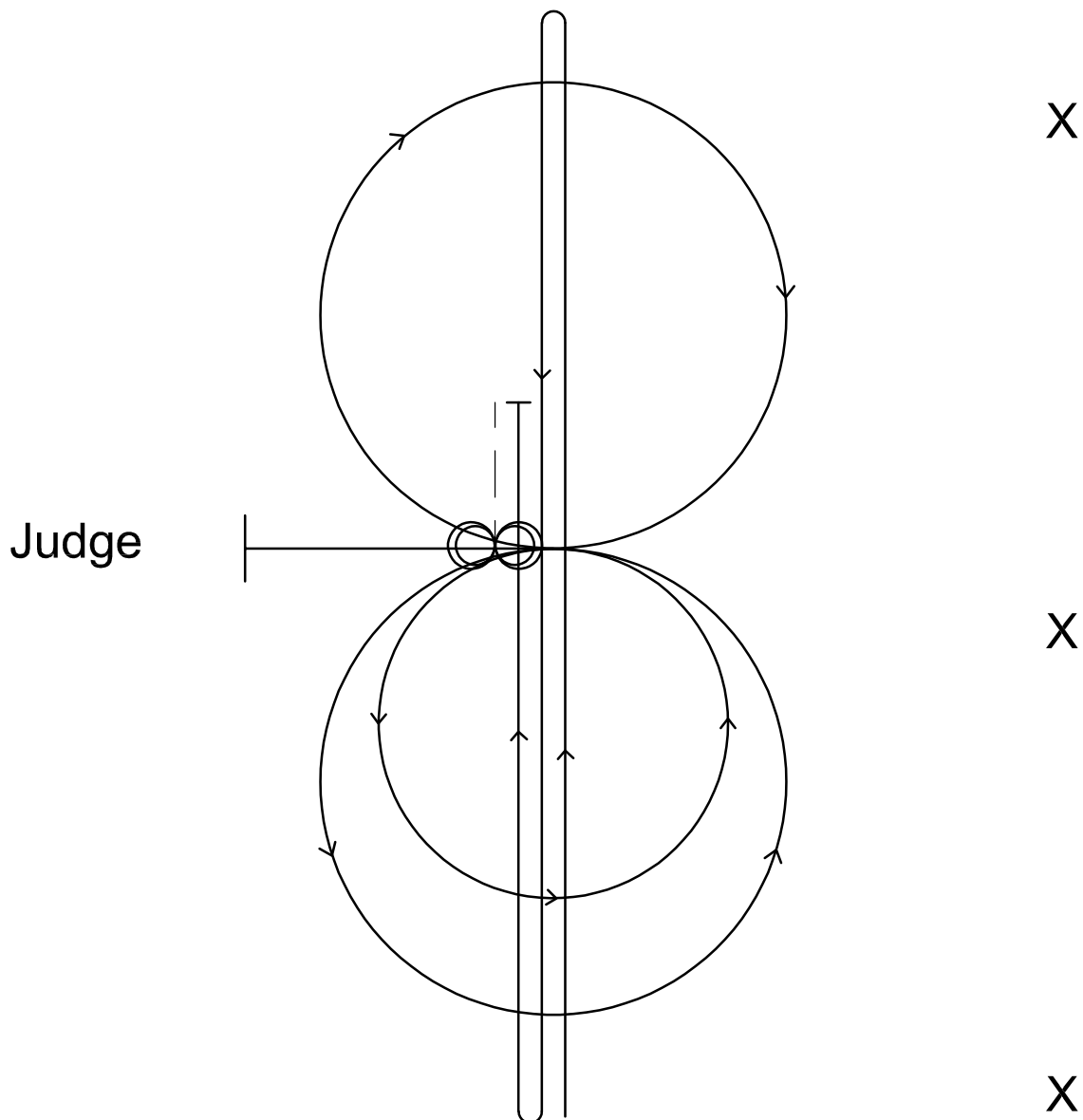

1. Run down to the far end with speed and perform a left rollback.
2. Run to the opposite end with speed and perform a right rollback.
3. Run past the center marker and stop. Back to the center. Hesitate
4. Complete two spins to the right.
5. Complete two and a quarter spins to the left.
6. Beginning on the left lead, complete a small, slow circle to the left.
7. Change leads at the center.
8. Complete a larger circle with speed to right.
9. Change leads at the center.
10. Complete a larger circle with speed to the left.
11. Ride past the center of the circles and stop. Hesitate to complete pattern.

GREELEY SADDLE CLUB

Trail - Age Groups 5 & Under, 6-9, & Novice

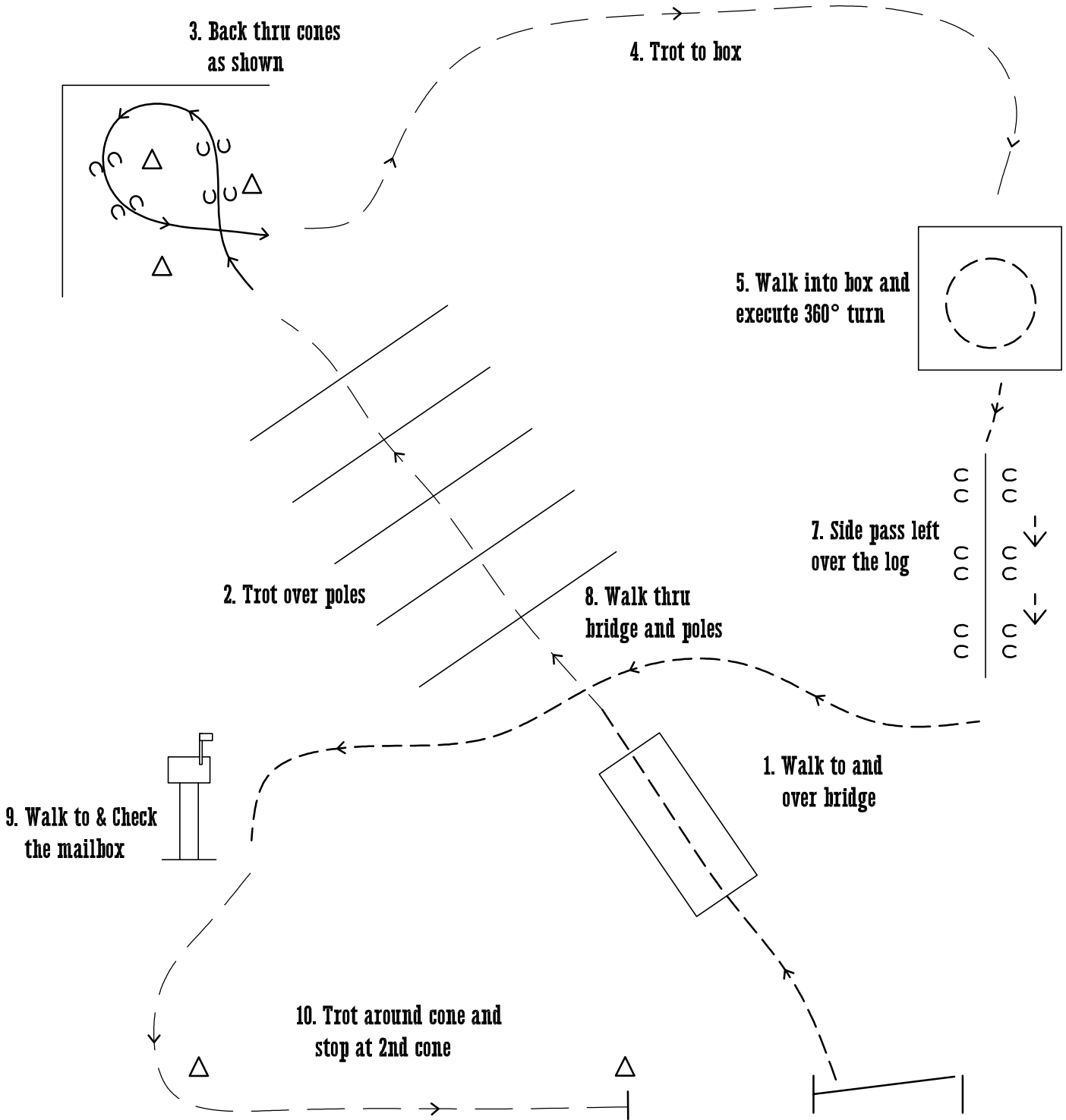

GREELEY SADDLE CLUB

Trail - Age Groups 10-13, 14-18, 19-39, 40 & Over

