

GREELEY SADDLE CLUB

English Equitation - All Ages

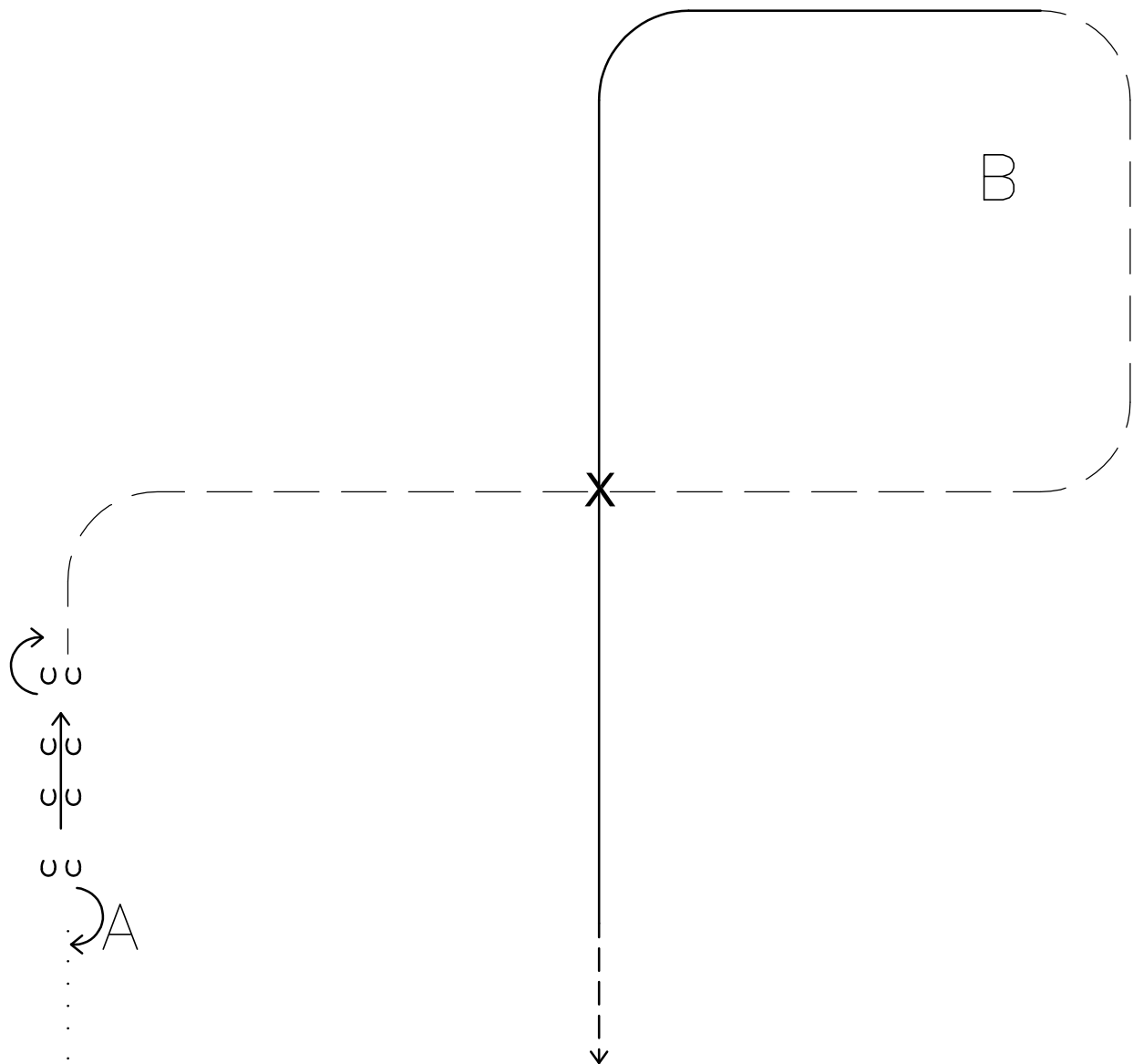

1. Be ready before A. Walk to A.
2. Perform a 180° right forehand turn.
3. Back approximately one horse length.
4. Perform a 180° left forehand turn.
5. Posting trot on the left diagonal to the center of the pattern.
6. Change diagonals at the center and trot to B as shown.
7. Canter on the left lead to the center of of the pattern as shown.
8. Change leads and canter on the right lead until even with A.
9. When even with A, sitting trot back to line up.

GREELEY SADDLE CLUB

Showmanship - Age Groups 5 & Under, 6-9, & 10-13

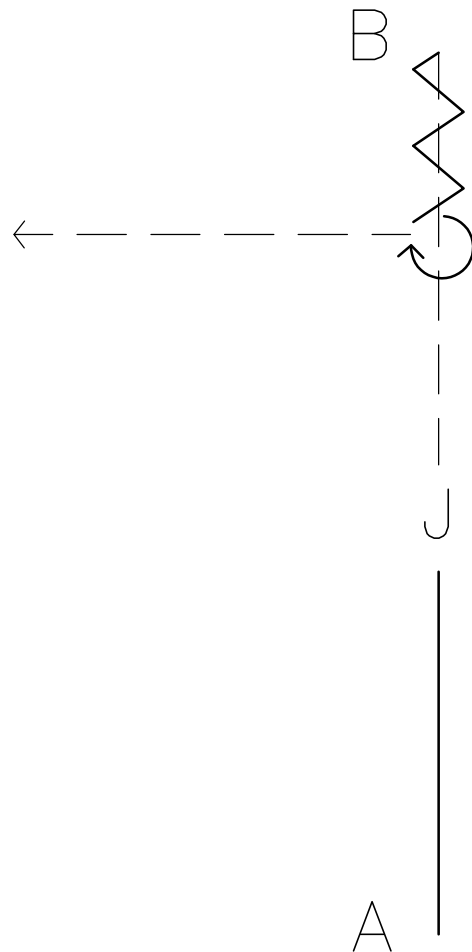

1. Start at A.
2. Walk to the Judge and set up for inspection.
3. When dismissed, trot to B.
4. Stop. Back 4 steps.
5. Complete a 270° turn.
6. Trot to line up.

GREELEY SADDLE CLUB

Showmanship - Age Groups 14-18, 19-39, 40 & Over

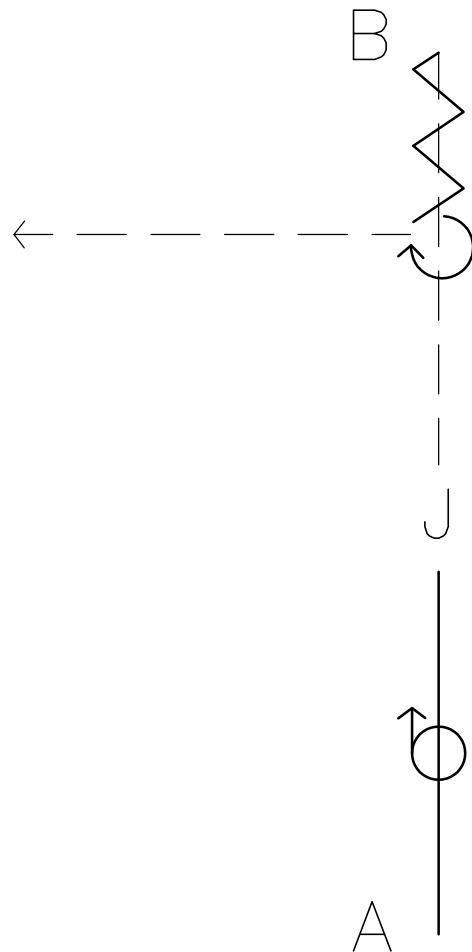

1. Start at A.
2. Walk halfway to the Judge and complete a 360° turn.
3. Continue walking to the judge and set up for inspection.
4. When dismissed, trot to B.
5. Stop. Back 4 steps.
6. Complete a 270° turn.
7. Trot to line up.

GREELEY SADDLE CLUB

Horsemanship - Age Groups 6-9 & 10-13

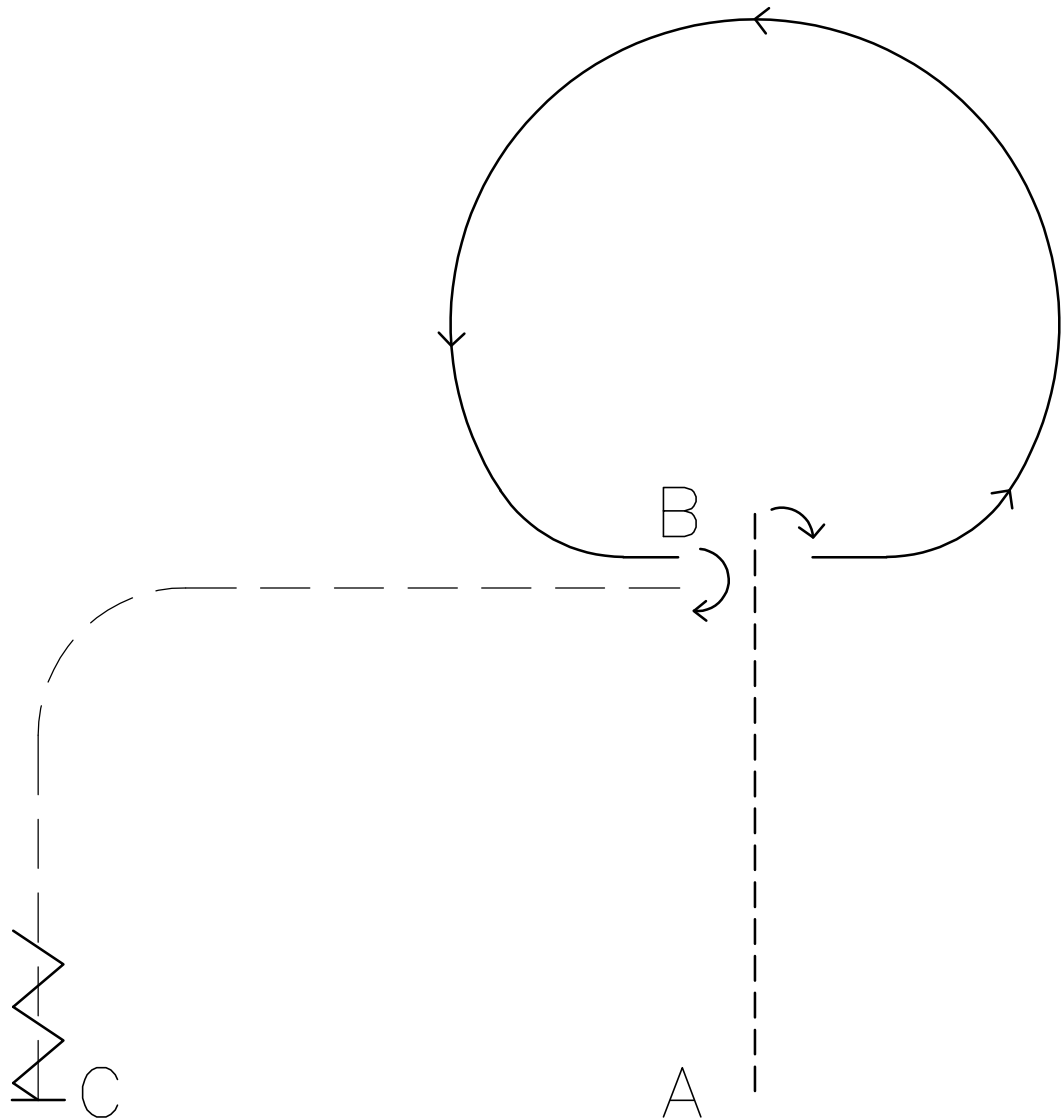

1. Start at A and jog to B.
2. Stop at B and perform a 90° turn to the right.
3. Lope a circle on the left lead around B.
4. Stop at B. Perform a 180° turn to the right.
5. Extended jog straight away from B and toward C as shown.
6. Stop at C. Back 5 steps.

GREELEY SADDLE CLUB

Horsemanship - Age Groups 14-18, 19-39, 40 & Over

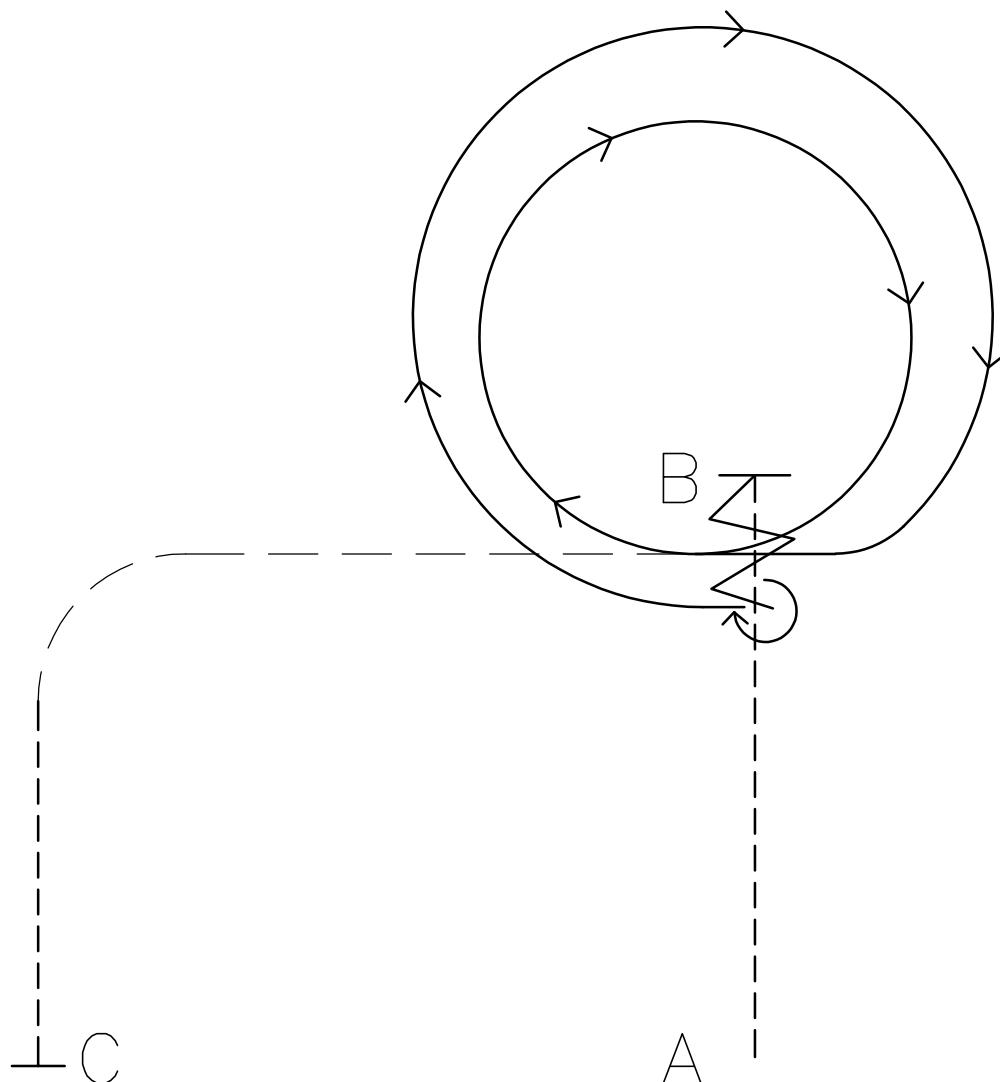

1. Start at A and jog to B.
2. Stop at B and back 5 steps. Perform a 270° turn to the right.
3. Complete a circle around B at an extended lope on the right lead.
4. Continue a second smaller circle around B at a collected lope.
5. At B, break down to an extended jog straight away from B.
6. Turn toward C as shown at a collected jog.
7. Stop at C.

GREELEY SADDLE CLUB

Reining - Age Group 6-9

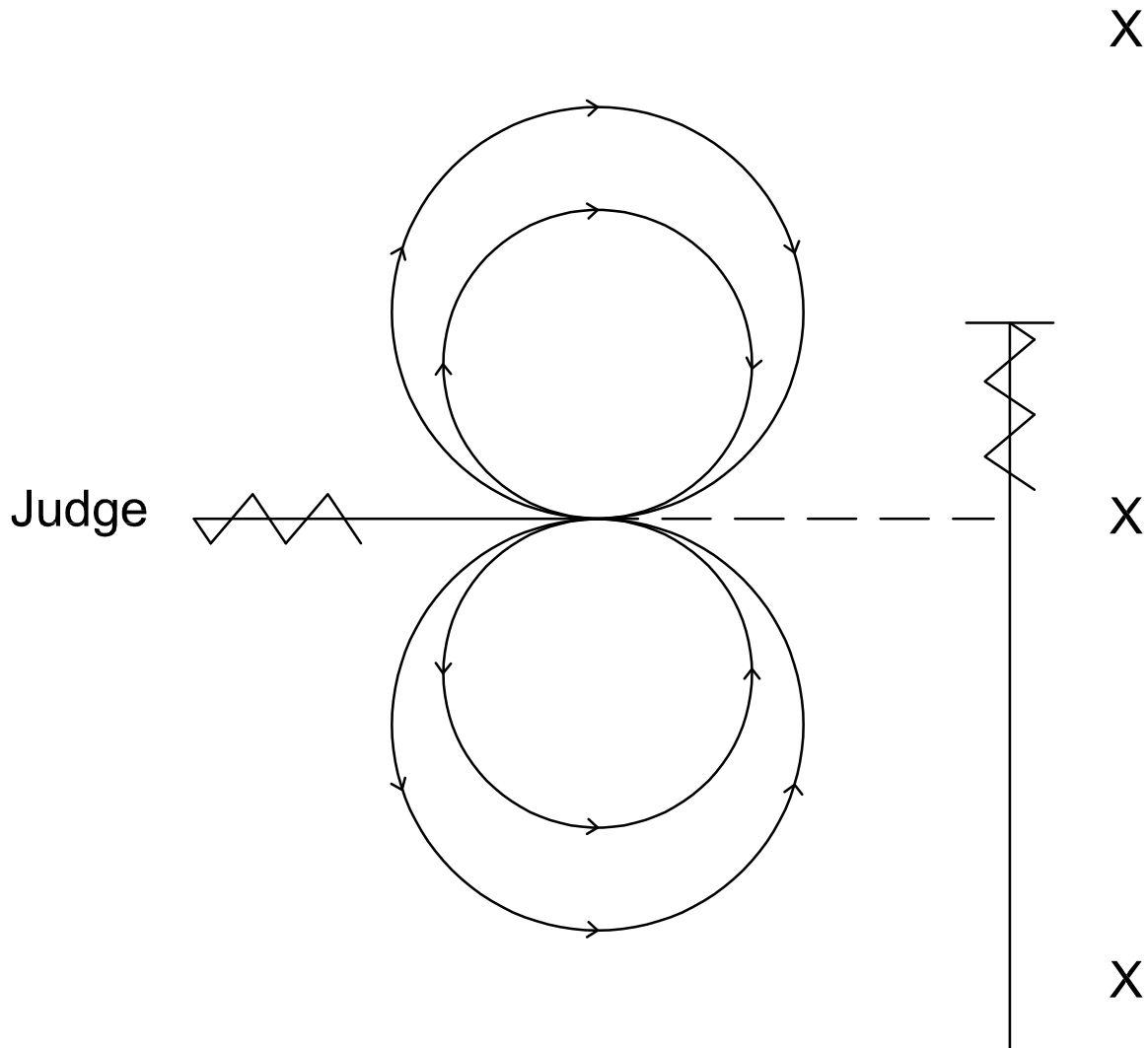

1. Lope in a straight line at least 20 feet from the fence.
2. Stop past the center marker and back in a straight line to the center.
3. Hesitate. Turn to the left 90°.
4. Lope two circles to the right with the first being smaller and slower than the second.
5. Change leads. Lope two circles to the left with the first being smaller and slower than the second.
6. Continue straight for 10 feet. Stop. Back.
7. Walk to the judge for inspection.

GREELEY SADDLE CLUB

Reining - Age Groups 10-13, 14-18, 19-39, 40 & Over

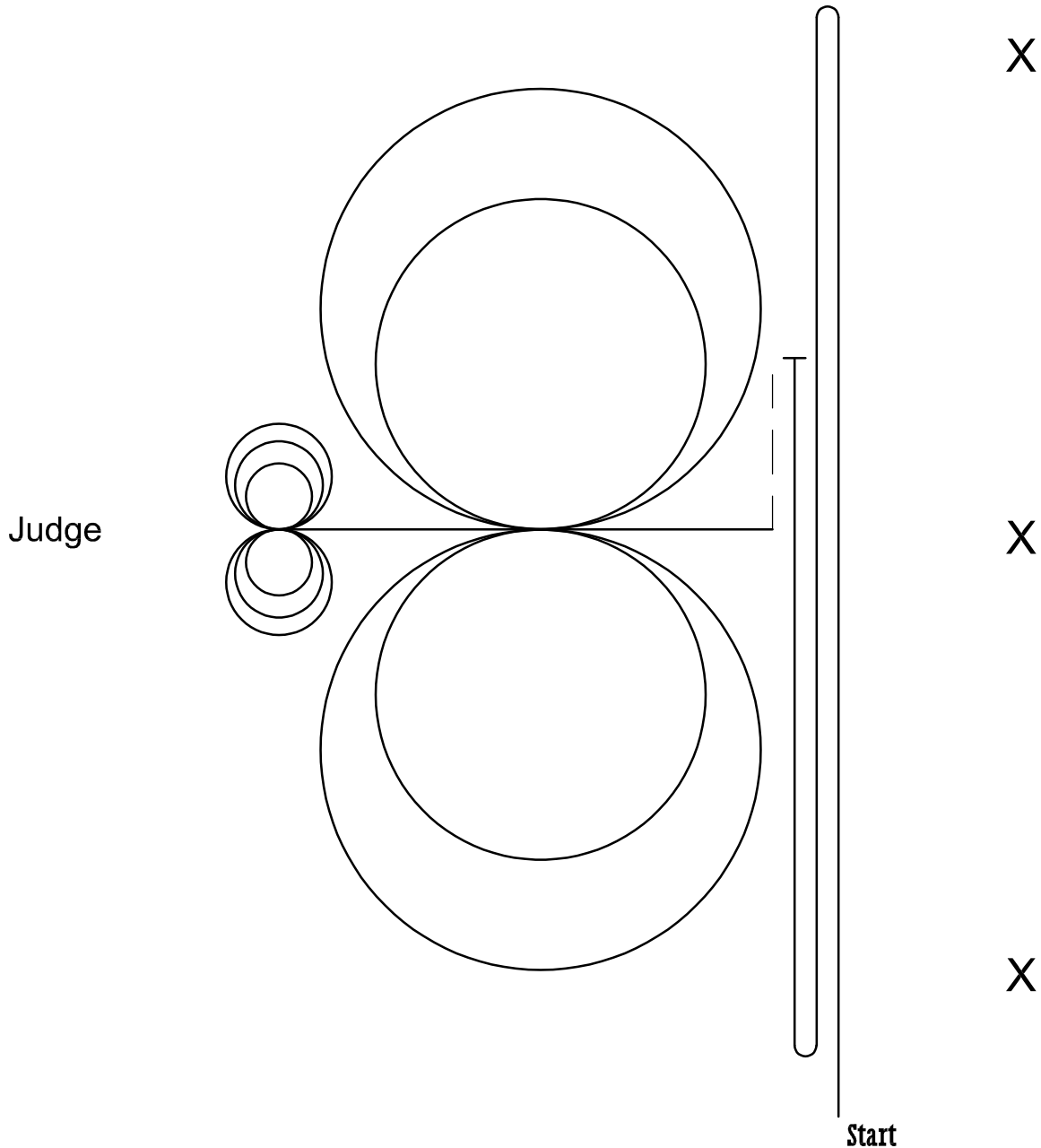

1. Start on the right side of the arena. Run down and roll back left past the end marker.
2. Run down and roll back right past the end marker.
3. Run past the center marker and stop. Back to the center. Turn 90° to face the center of the arena.
4. Complete two circles to the left with the first being small, slow and the second larger and faster.
5. Change leads at the center of the arena.
6. Complete two circles to the right with the first being small, slow and the second larger and faster.
7. Stop just past the center of the arena. Complete three spins to the right.
8. Hesitate. Complete three spins to the left.

GREELEY SADDLE CLUB

Trail - Age Groups 5 & Under, 6-9, & Novice

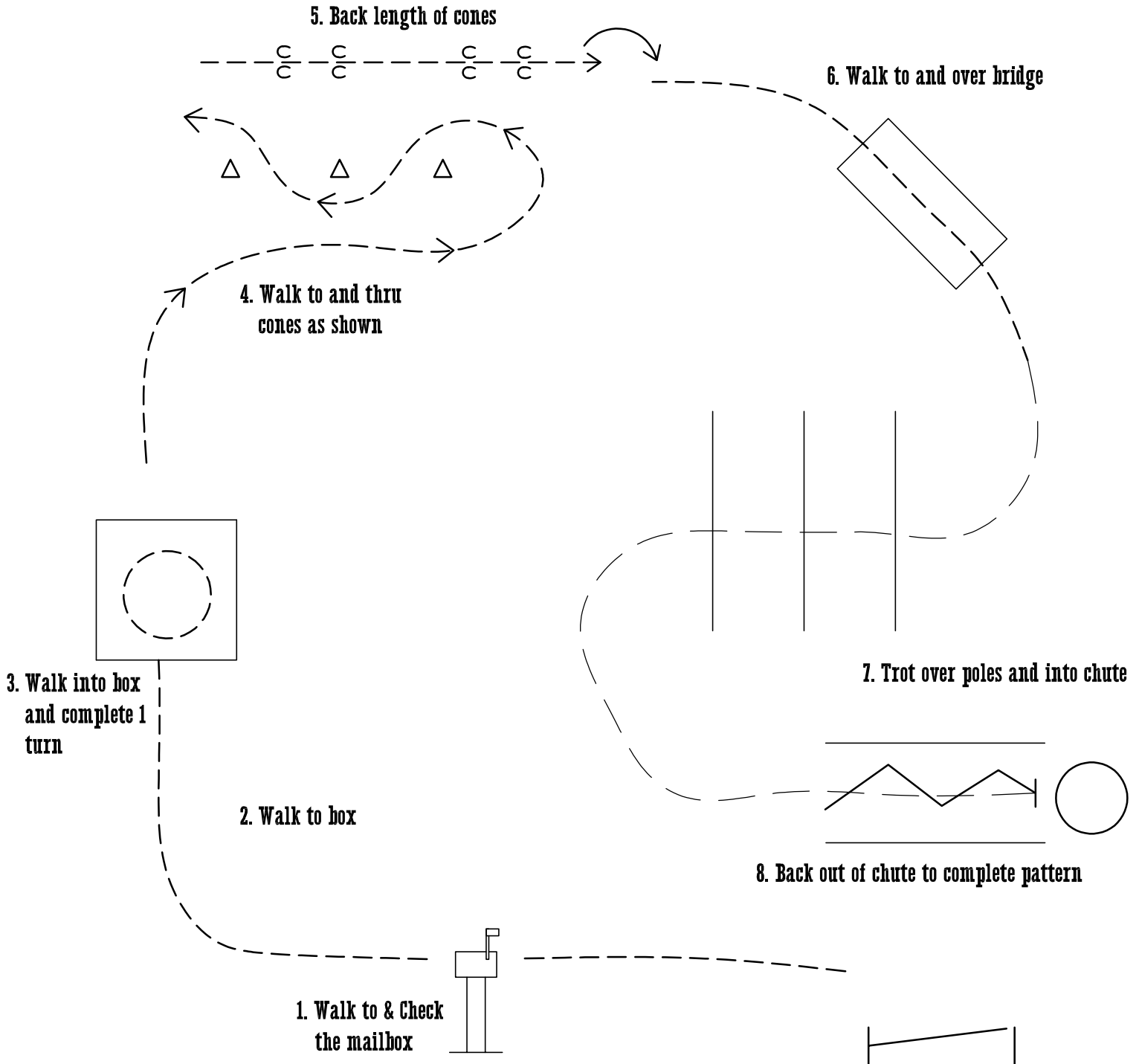

GREELEY SADDLE CLUB

Trail - Age Groups 10-13, 14-18, 19-39, 40 & Over

