

GREELEY SADDLE CLUB

Showmanship - Age Groups 5 & Under, 6-9, & 10-13

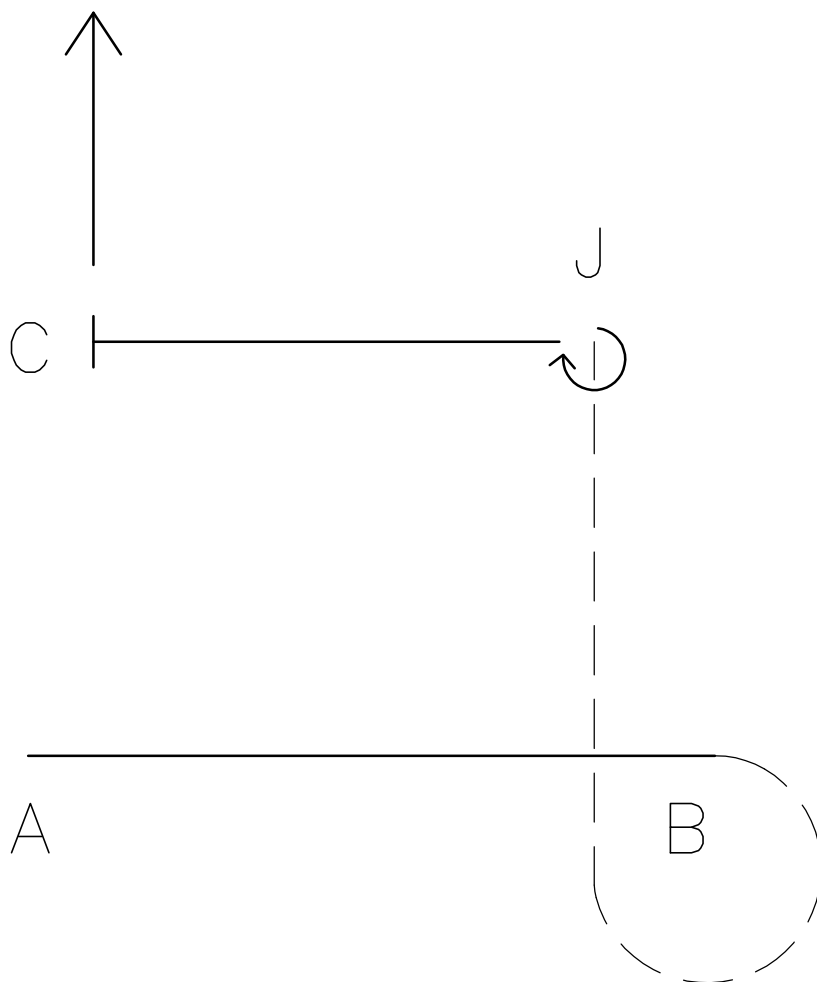

1. Start at A. Walk to B.
2. Trot around B and continue on to the Judge.
3. At the Judge, set up for inspection.
4. When dismissed, complete a 270° turn and walk to C.
5. Stop at C to complete your pattern. Line up on the opposite end of the arena.

GREELEY SADDLE CLUB

Showmanship - Age Groups 14-18, 19-39, 40 & Over

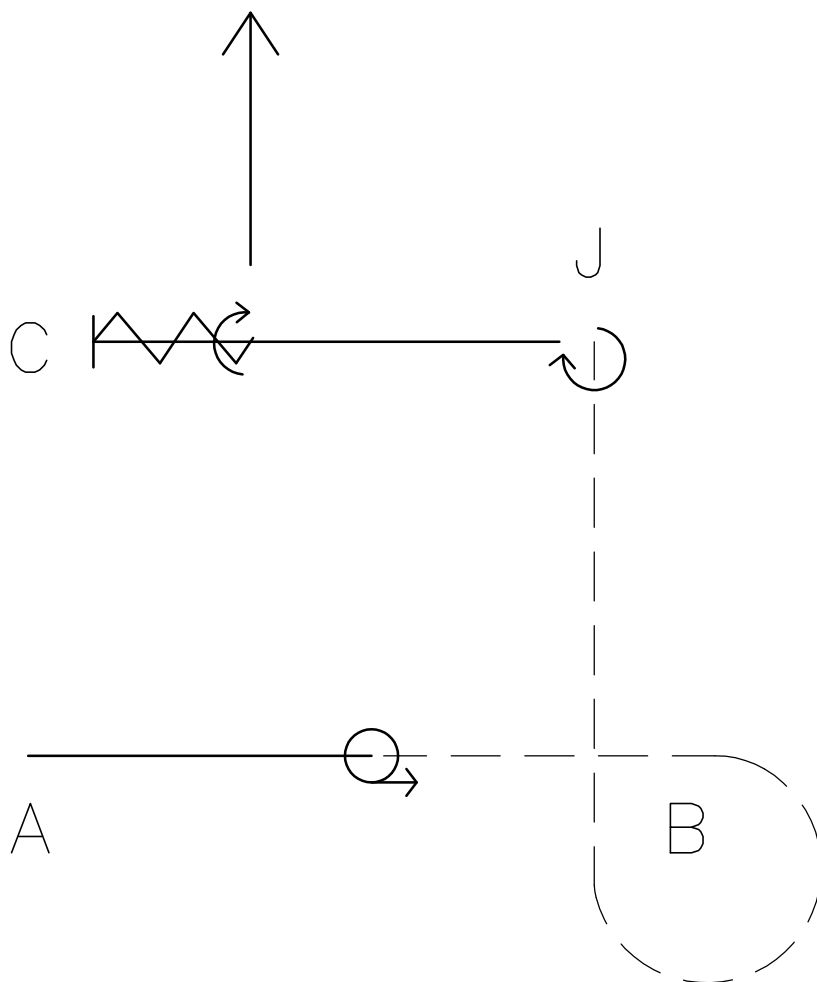

1. Start at A. and walk towards B.
2. Halfway to B complete a 360° turn.
3. Trot to and around B as shown. Continue to the Judge.
4. At the Judge, set up for inspection.
5. When dismissed, complete a 270° turn and walk to C.
6. Stop at C. Back 5 steps. Execute a 90° turn to exit to the line up.

GREELEY SADDLE CLUB

English Equitation - All Ages

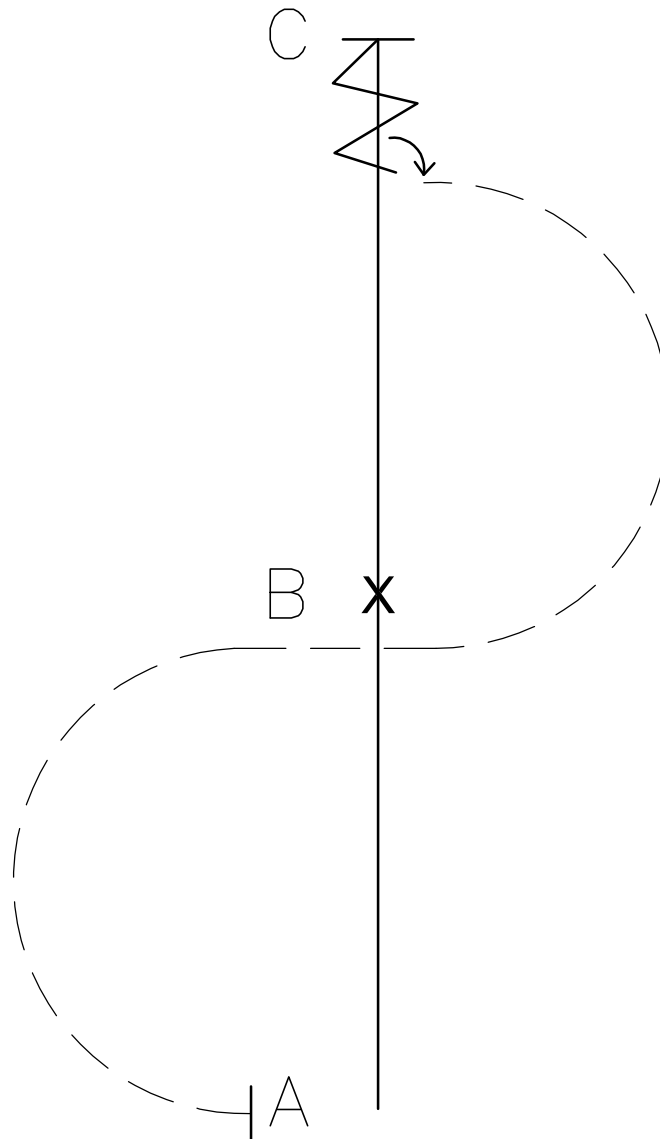

1. Start at A. Pick up a left lead canter to Marker B.
2. At B do a simple lead change to a right lead canter to C.
3. At C, halt and back 5 steps.
4. Perform a 90° turn on the forehand to the right.
5. Begin a posting trot half circle on the left diagonal to B.
6. At B, change diagonals and complete a half circle posting trot to A.
7. Stop at A.

GREELEY SADDLE CLUB

Horsemanship - Age Groups 6-9 & 10-13

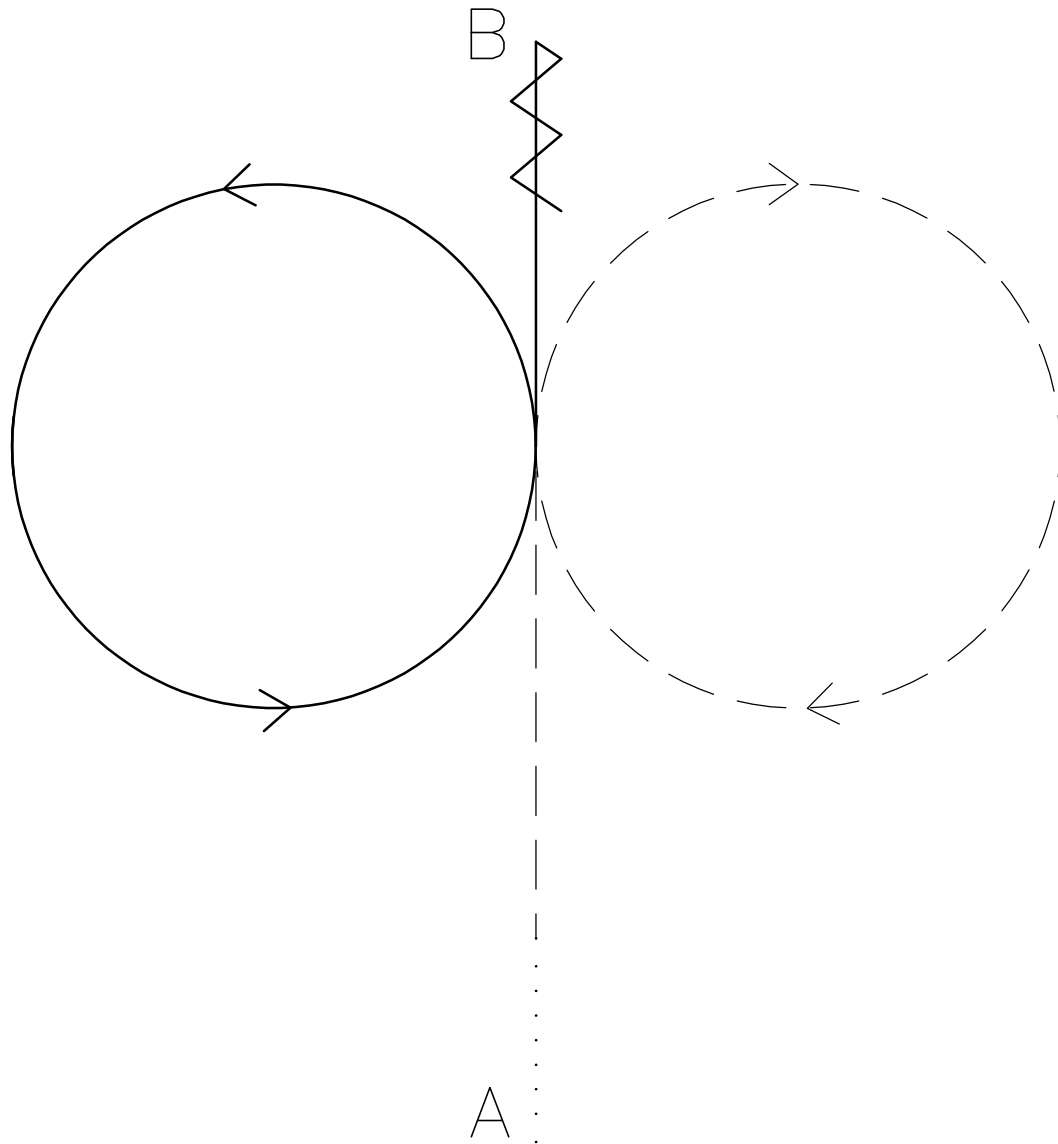

1. Walk just past A then jog towards B.
2. Jog a circle to the right between A and B.
3. Lope a circle to left on the left lead between A and B. Continue to B.
4. Stop at B. Back 5 steps.
5. Jog to return to line up.

GREELEY SADDLE CLUB

Horsemanship - Age Groups 14-18, 19-39, 40 & Over

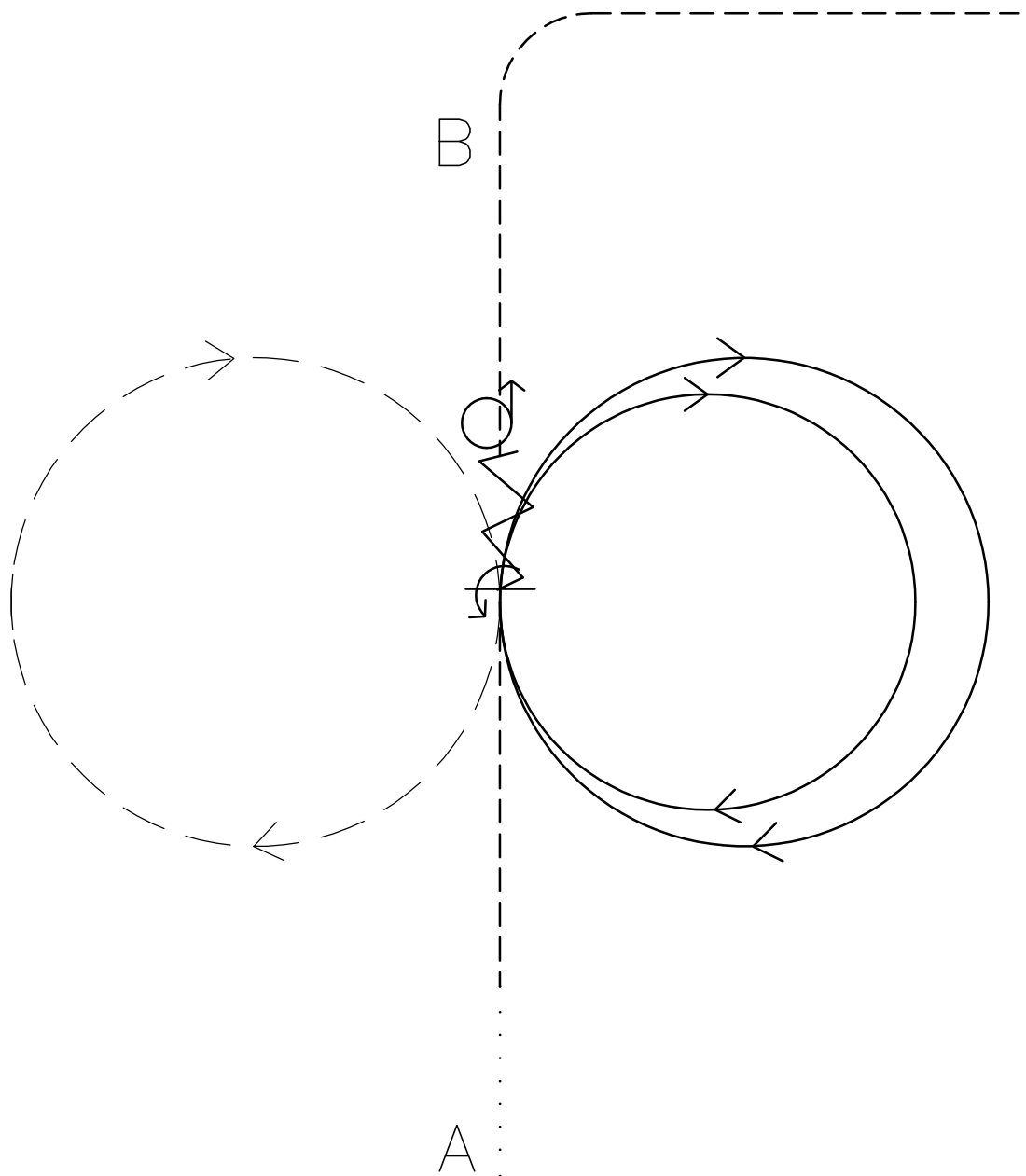

1. Walk just past A then jog towards B.
2. Between B and A, lope a circle to the right on the right lead followed by a faster larger circle.
3. Stop at the center. Complete a half turn to the left.
4. Extended jog a circle to the right. Stop at the center.
5. Back one horse length. Complete a one and half turn to the right.
6. Jog towards B and continue to jog to line up.

GREELEY SADDLE CLUB

Reining - Age Group 6-9

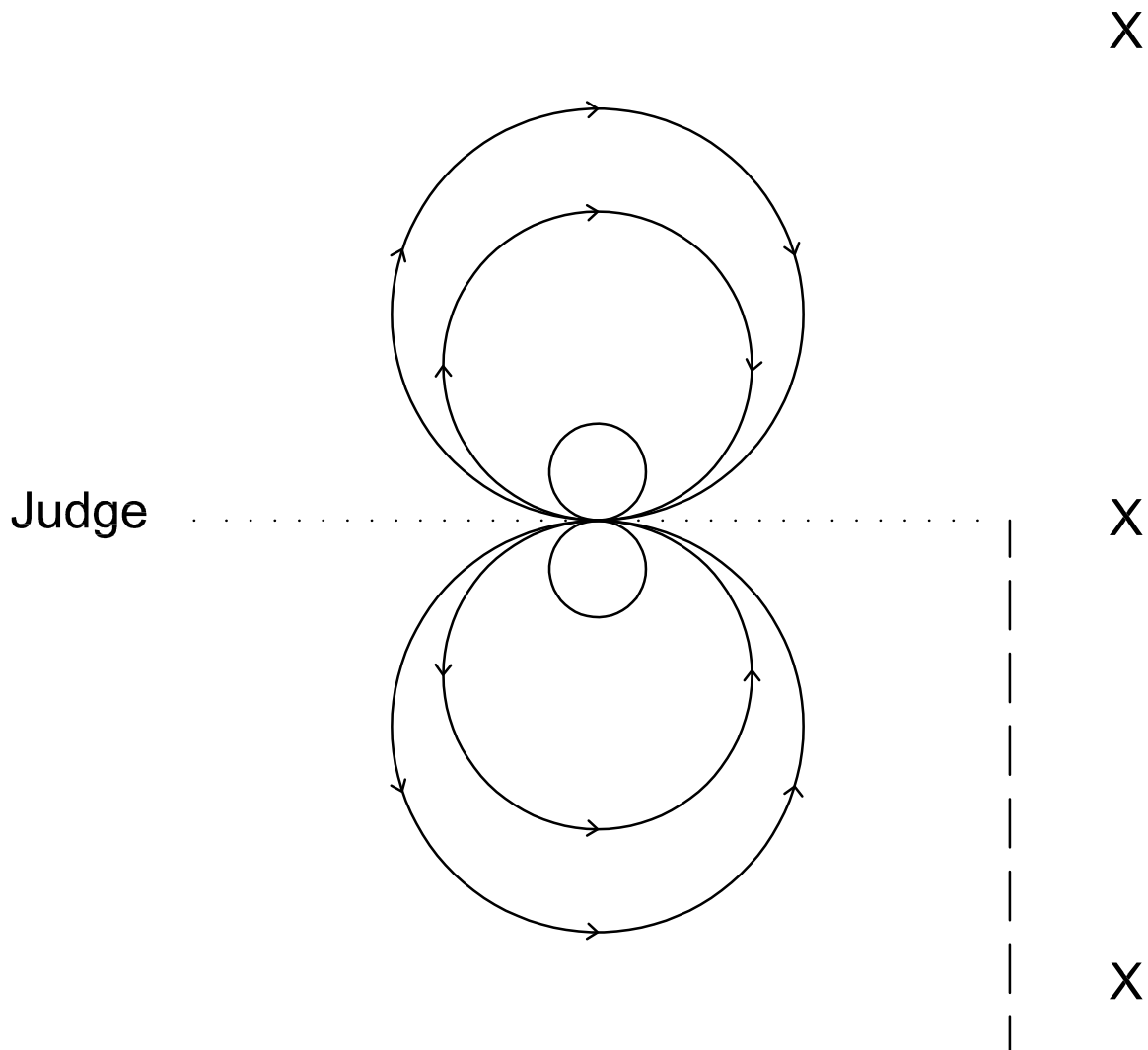

1. Trot in a straight line to the center marker, at least 20 feet from the rail.
2. Gradual stop through the walk.
3. Turn left, walk to center.
4. Lope two circles to the right with the first smaller and slower than the second.
5. At the center, stop and complete a 360° turn to the right.
6. Lope two circles to the left with the first smaller and slower than the second.
7. At the center, stop and complete a 360° turn to the left.
8. Walk to the judge for inspection.

GREELEY SADDLE CLUB

Reining - Age Groups 10-13, 14-18, 19-39, 40 & Over

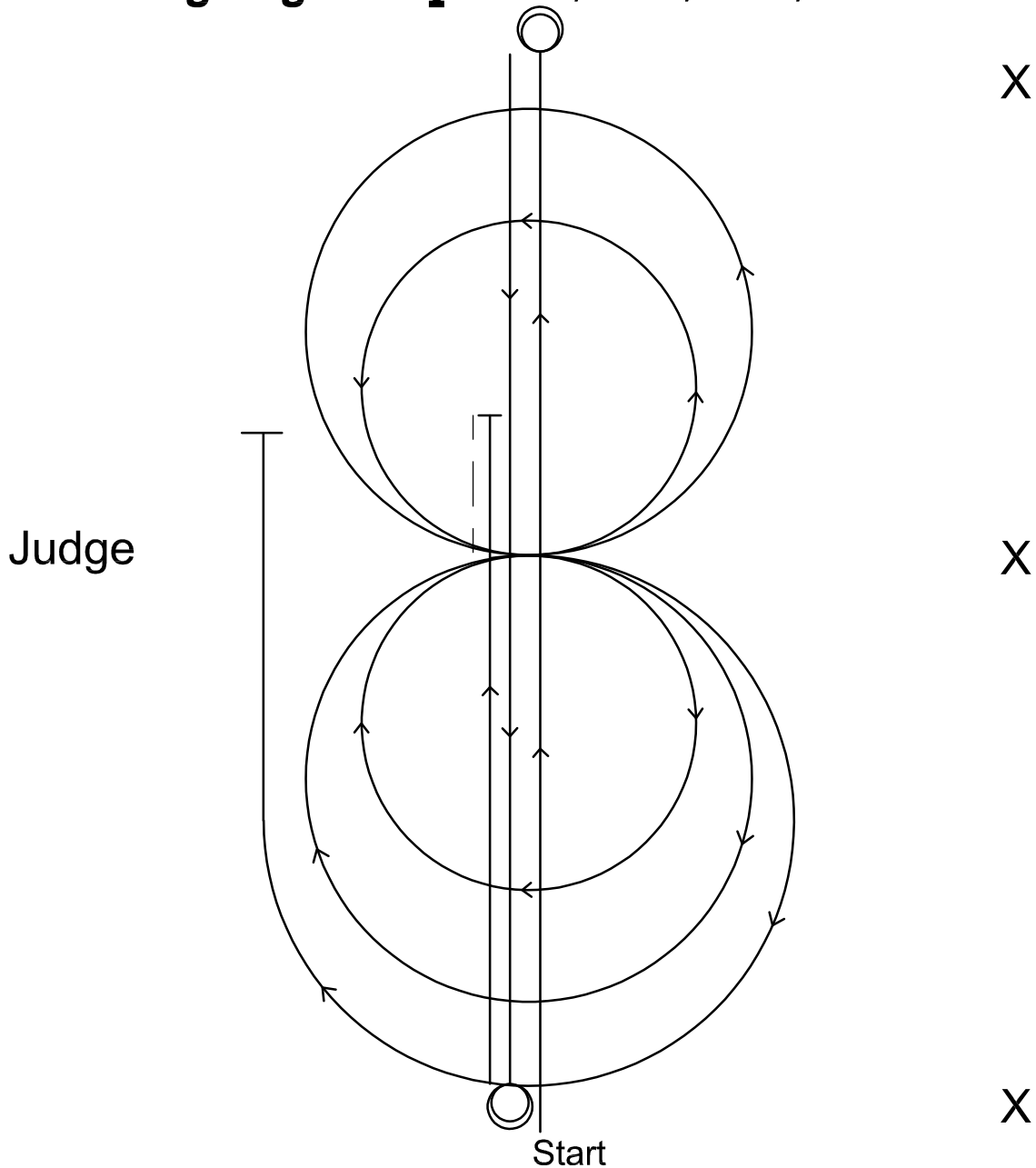

1. Run to the far end of the arena, stop and complete 2 1/2 spins to the left.
2. Run to the opposite end of the arena, stop and complete 2 1/2 spins to the right.
3. Run past the center of the arena, stop and back to the center. Hesitate.
4. Pivot 90 to the right. Run two circles to the right with the first being smaller and slower and the second larger and faster.
5. Change leads at the center and complete two circles to the left the first smaller and slower and the second larger and faster.
6. Change leads at the center and start a circle to right, but do not close it. Run past the center marker and stop.

GREELEY SADDLE CLUB

Trail - Age Groups 5 & Under, 6-9, & Novice

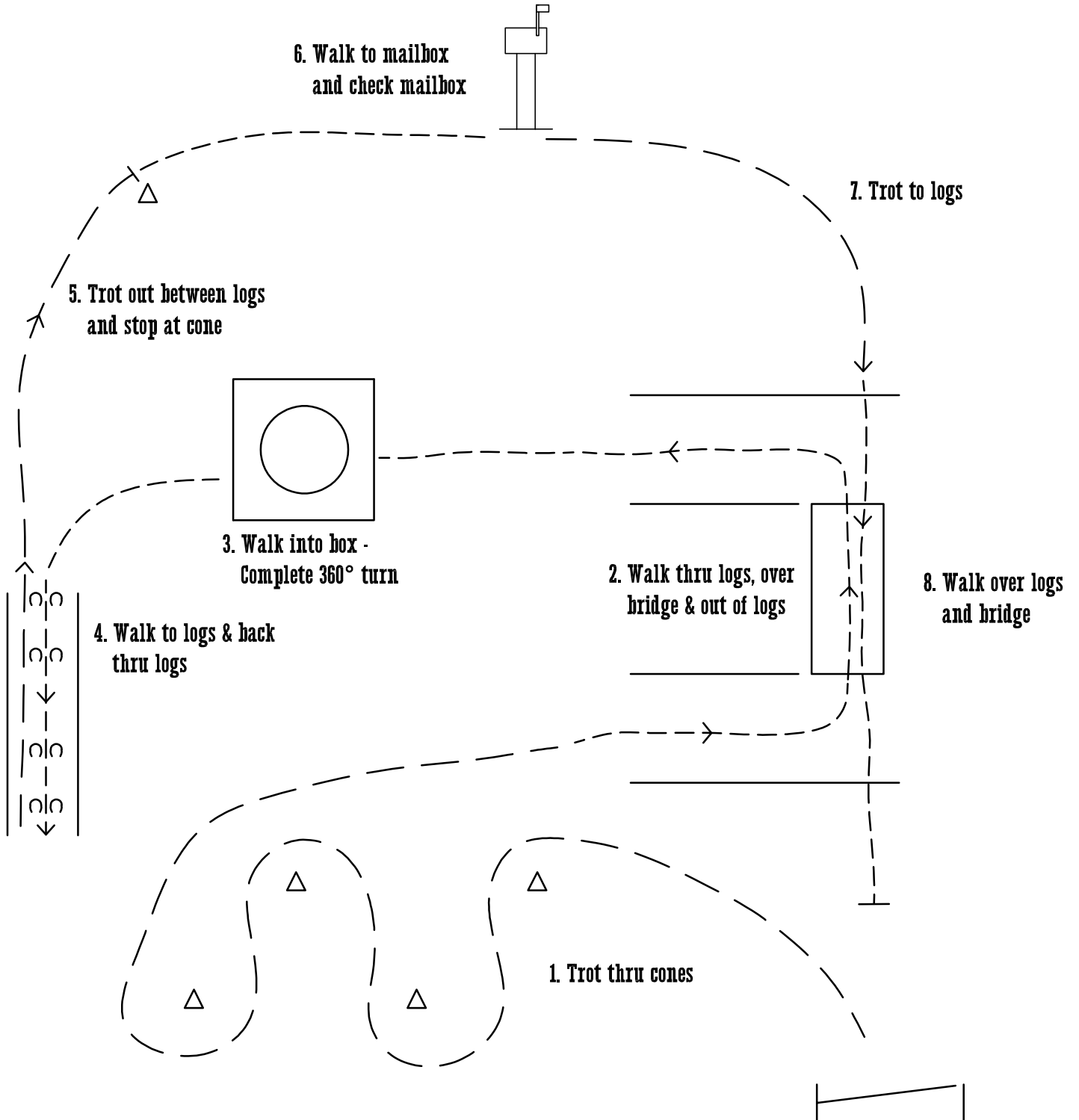

GREELEY SADDLE CLUB

Trail - Age Groups 10-13, 14-18, 19-39, 40 & Over

