

GREELEY SADDLE CLUB

Showmanship - Age Groups 5 & Under, 6-9, & 10-13

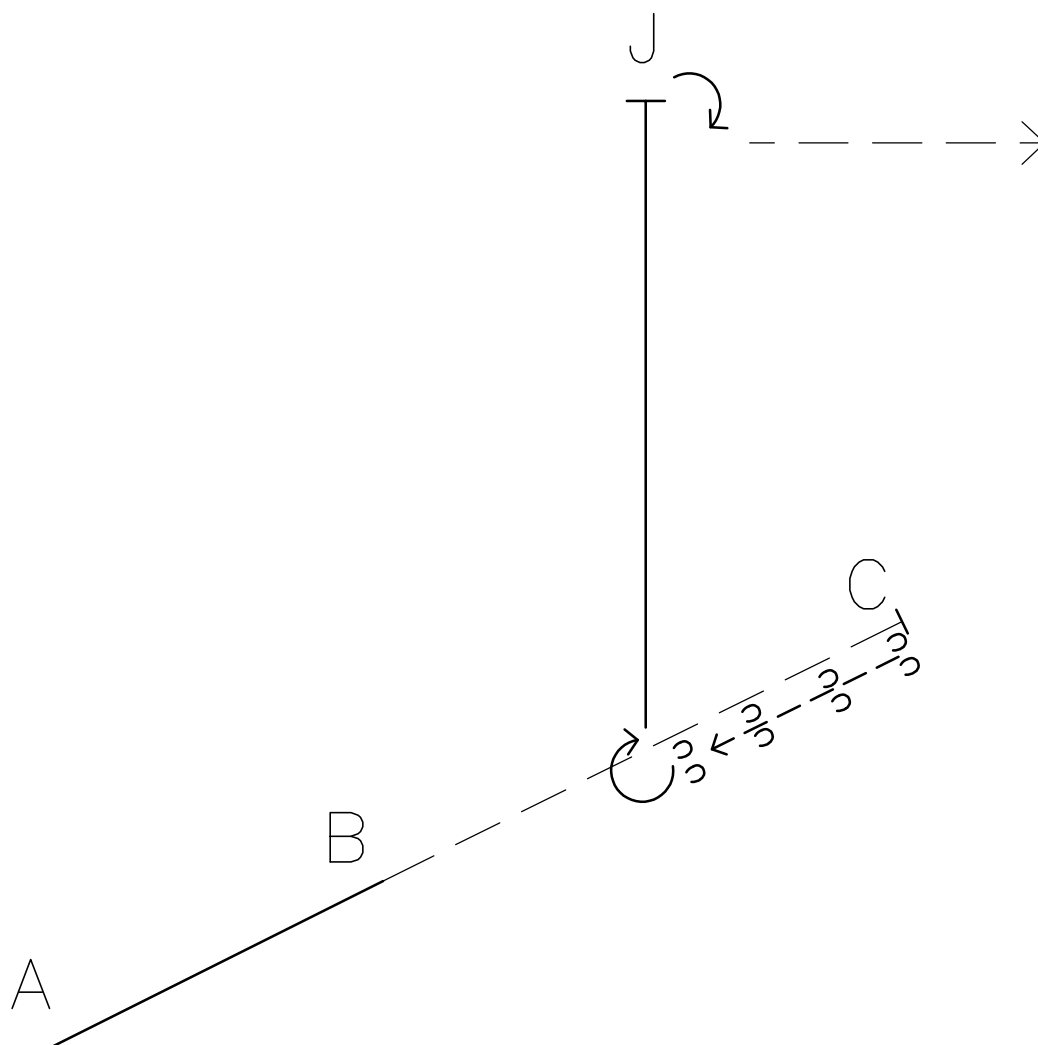

1. Start at A. Walk to B.
2. Trot from B to C.
3. Stop at C and back to align with the Judge.
4. Perform an approximate 300° turn toward the Judge.
5. Walk to the Judge. Set up for inspection.
6. When dismissed, perform a 90° turn and trot to line up.

GREELEY SADDLE CLUB

Showmanship - Age Groups 14-18, 19-39, 40 & Over

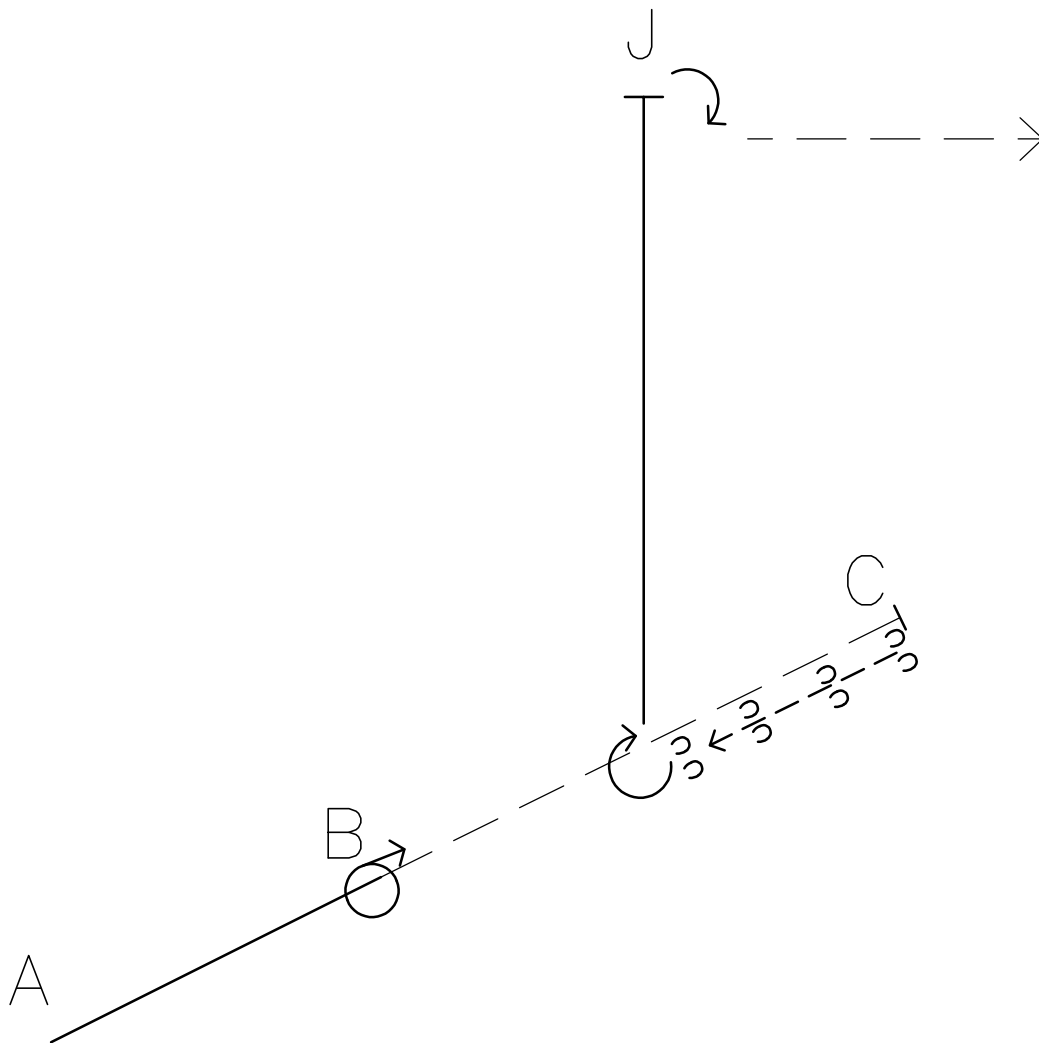

1. Start at A. Walk to B.
2. At B, perform a 360° turn.
3. Trot from B to C.
4. Stop at C and back to align with the Judge.
5. Perform an approximate 300° turn toward the Judge.
6. Walk to the Judge. Set up for inspection.
7. When dismissed, perform a 90° turn and trot to line up.

GREELEY SADDLE CLUB

English Equitation - All Ages

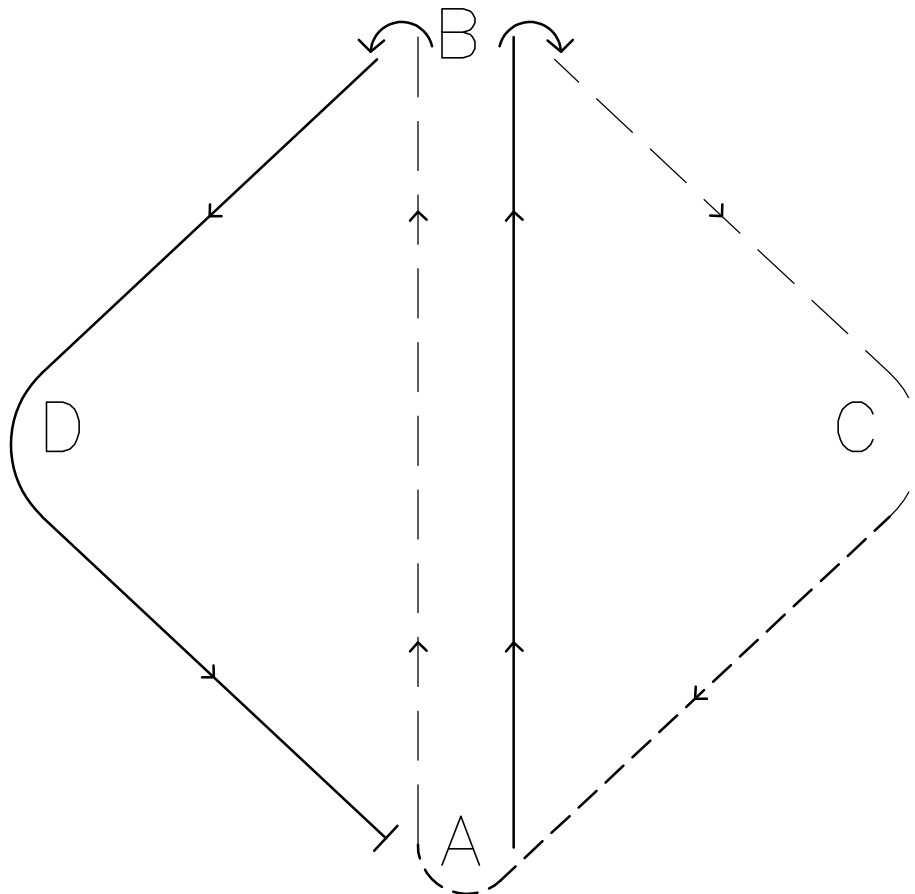

1. Start at A. Canter on the right lead to B.
2. Stop at B and complete a forehand turn to the right toward C.
3. Posting trot on the left diagonal to and around C.
4. Sitting trot from C to and around A.
5. At A, posting trot on the right diagonal back to B.
6. Stop at B and complete a hindquarter pivot to the left toward D.
7. Canter on the left lead to and around D toward A. Stop at A.

GREELEY SADDLE CLUB

Horsemanship - Age Groups 6-9 & 10-13

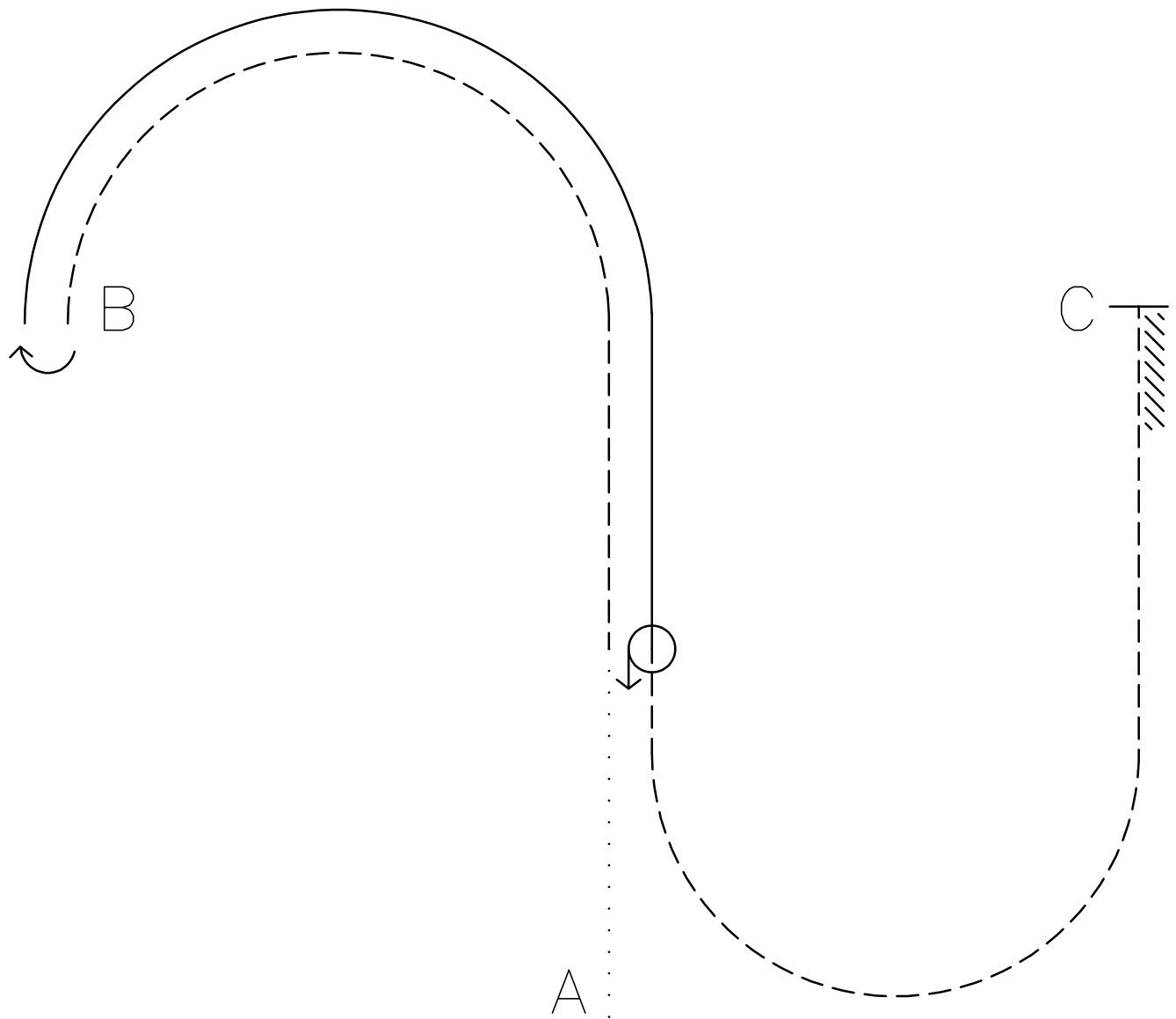

1. Walk straight from A. Jog straight and around to B as shown.
2. Stop at B. Complete a 180 turn to the right.
3. Lope on the right lead around and towards A.
4. Stop before A. Complete a 360 turn to the left.
5. Jog around to C as shown.
6. Stop at C. Back one horse length.

GREELEY SADDLE CLUB

Horsemanship - Age Groups 14-18, 19-39, 40 & Over

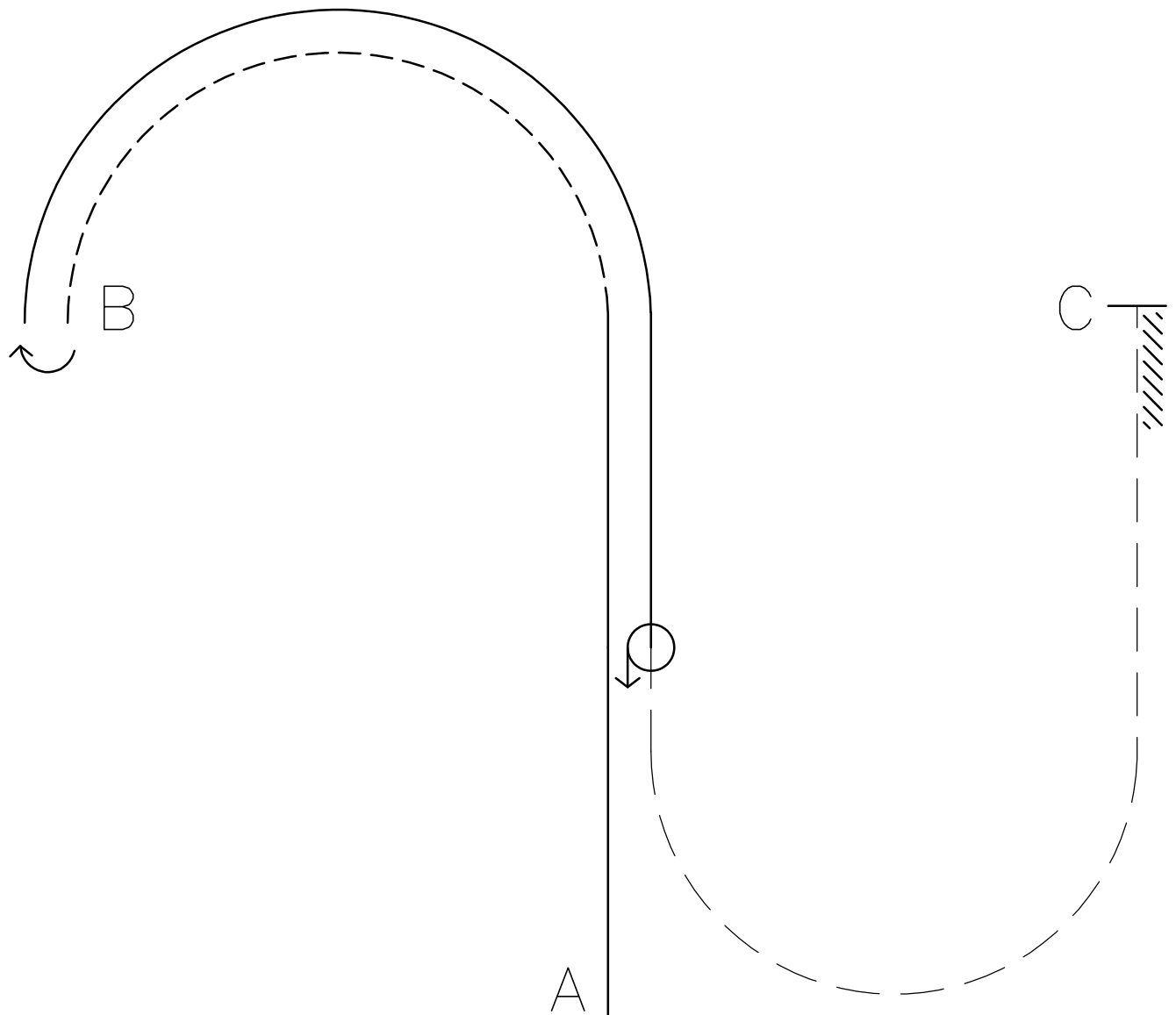

1. Lope on the left lead straight from A.
2. Break to a jog when even with B and jog around to B.
3. Stop at B. Complete a 180 turn to the right.
4. Lope on the right lead around and towards A.
5. Stop before A. Complete a 360 turn to the left.
6. Extended jog around to C as shown.
7. Stop at C. Back one horse length.

GREELEY SADDLE CLUB

Reining - Age Group 6-9

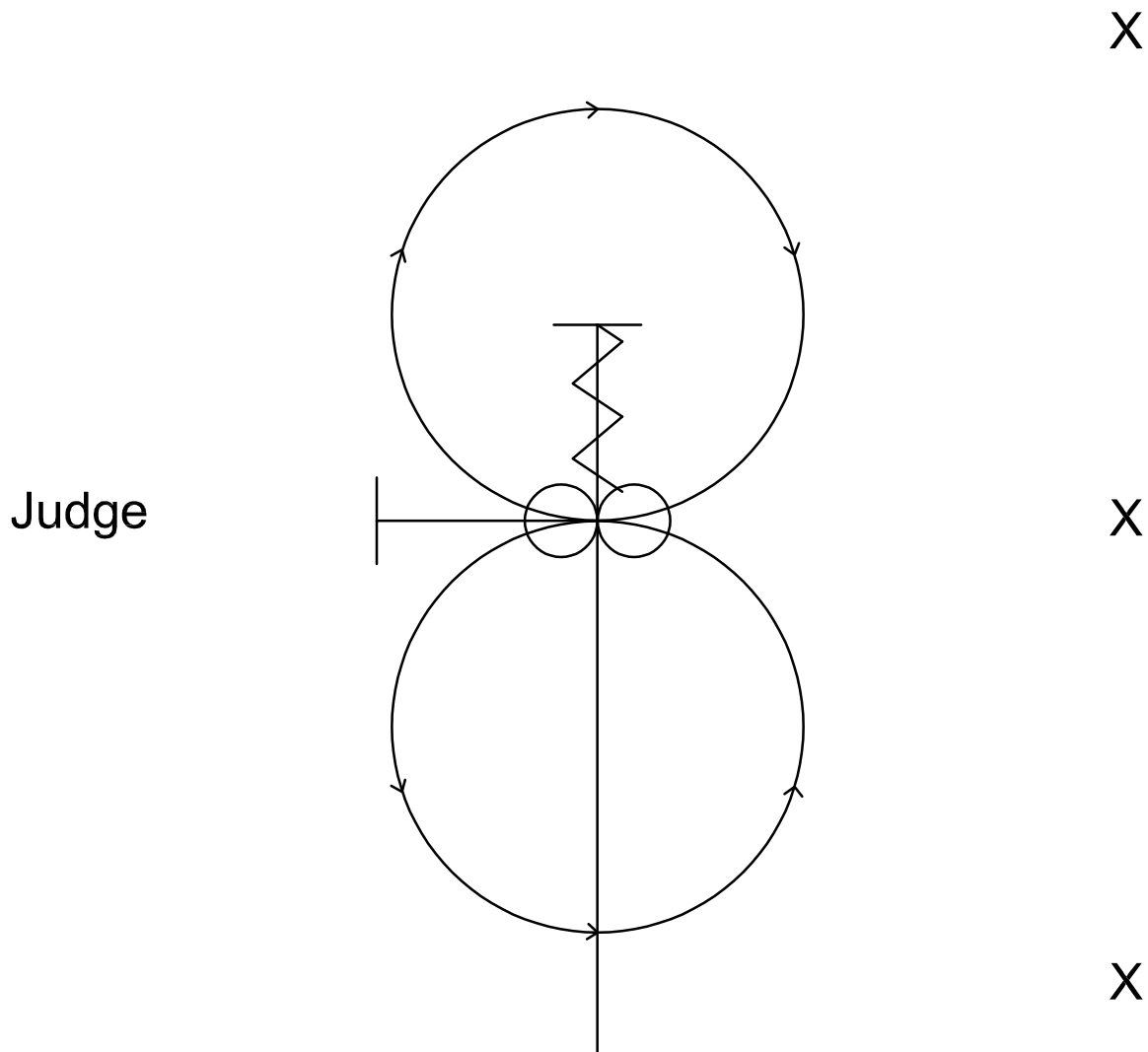

1. Lope in a straight line up the middle of the arena past the center marker. Stop.
2. Back at least 10 feet to the center.
3. Complete 1 spin to the right.
4. Complete 1 1/4 spins to the left.
5. Lope a figure 8 at moderate speed to the right first.
6. Continue straight for 10 feet.
7. Stop. Walk to the judge for inspection.

GREELEY SADDLE CLUB

Reining - Age Groups 10-13, 14-18, 19-39, 40 & Over

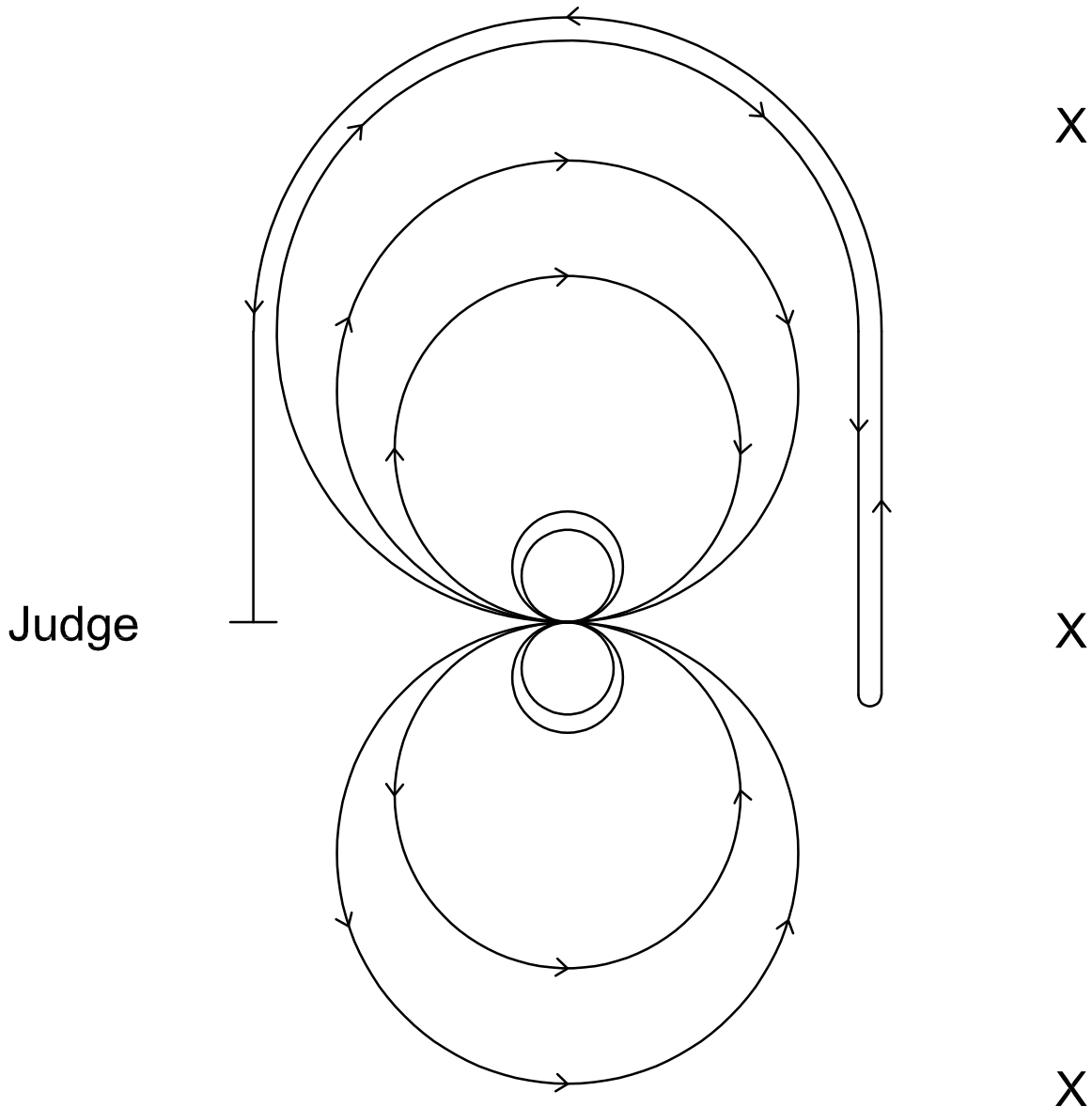

1. Jog to the center of the arena and face the judge waiting to start your pattern.
2. Complete two spins to the right.
3. Lope two circles to the right with the first being small and slow and the second being larger and faster.
4. Stop at the center of the arena and complete two spins to the left.
5. Complete two circles to the left with the first being larger and fast and the second smaller and slow.
6. Change leads at the center and start a circle to the right, but do not close it out. Run past the center marker, stop, and rollback towards the fence.
7. Run back around the arena past the center marker on the opposite side and complete a balanced stop.

GREELEY SADDLE CLUB

Trail - Age Groups 5 & Under, 6-9, & Novice

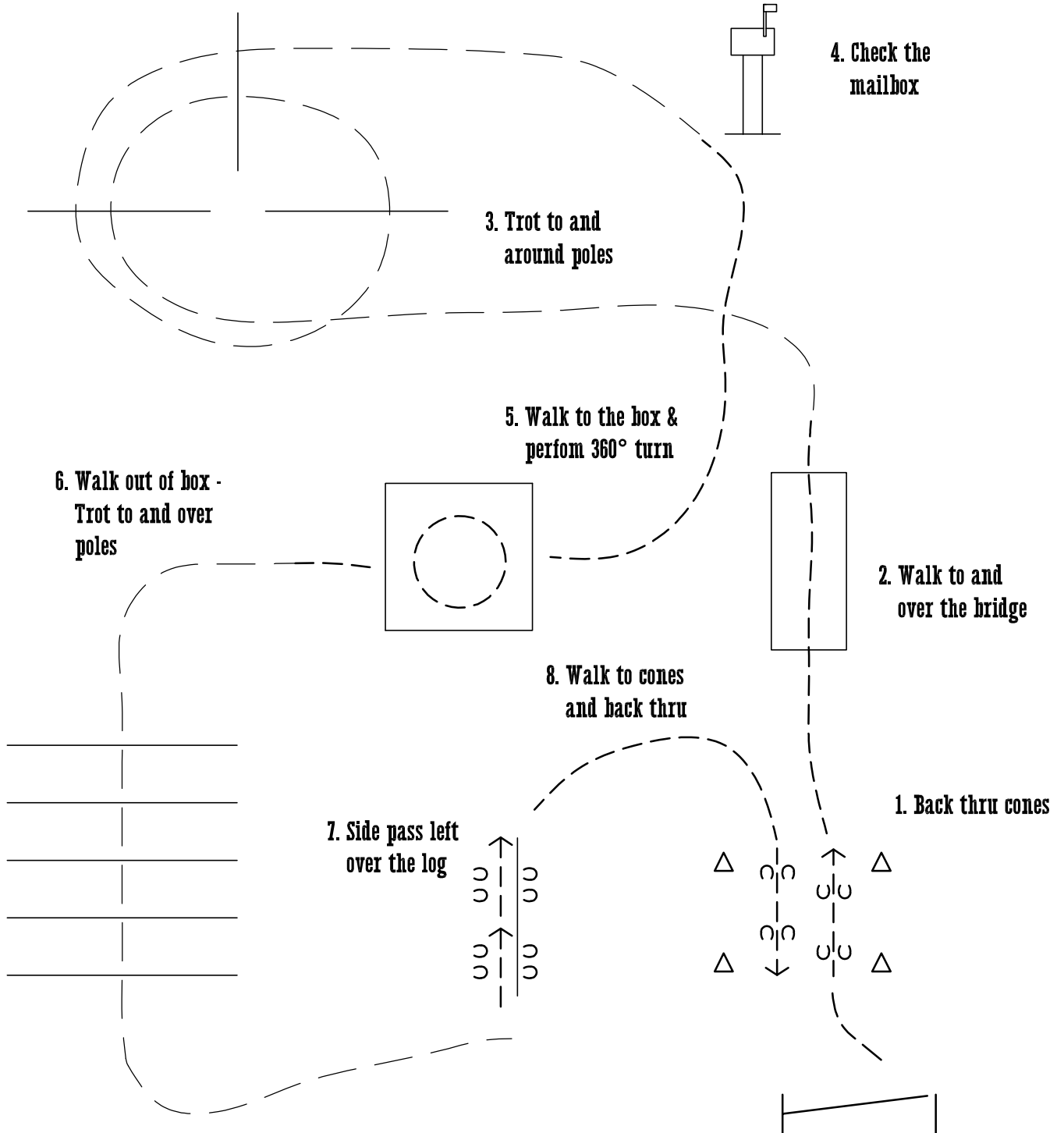

GREELEY SADDLE CLUB

Trail - Age Groups 10-13, 14-18, 19-39, 40 & Over

