

GREELEY SADDLE CLUB

Ranch Pleasure - Green Horse and Youth 13 & Under

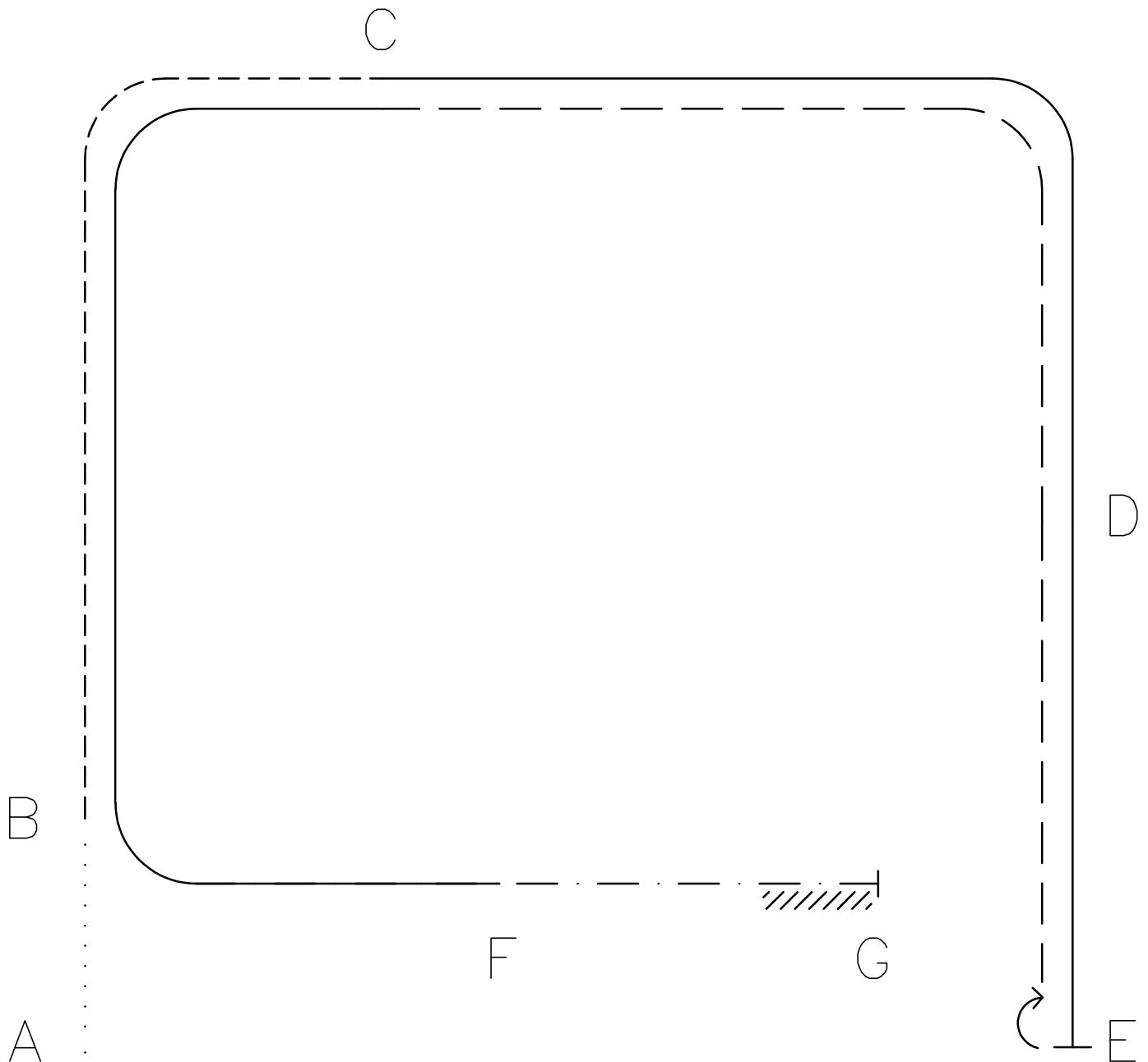

1. **A to B - Walk**
2. **B to C - Trot**
3. **C to E - Lope**
4. **Stop & Reverse**
5. **E to C - Extended trot**
6. **C to F - Lope**
7. **F to G - Extended Walk**
8. **Stop and Back**

GREELEY SADDLE CLUB

Ranch Pleasure - Youth 14-18, Amateur, Open

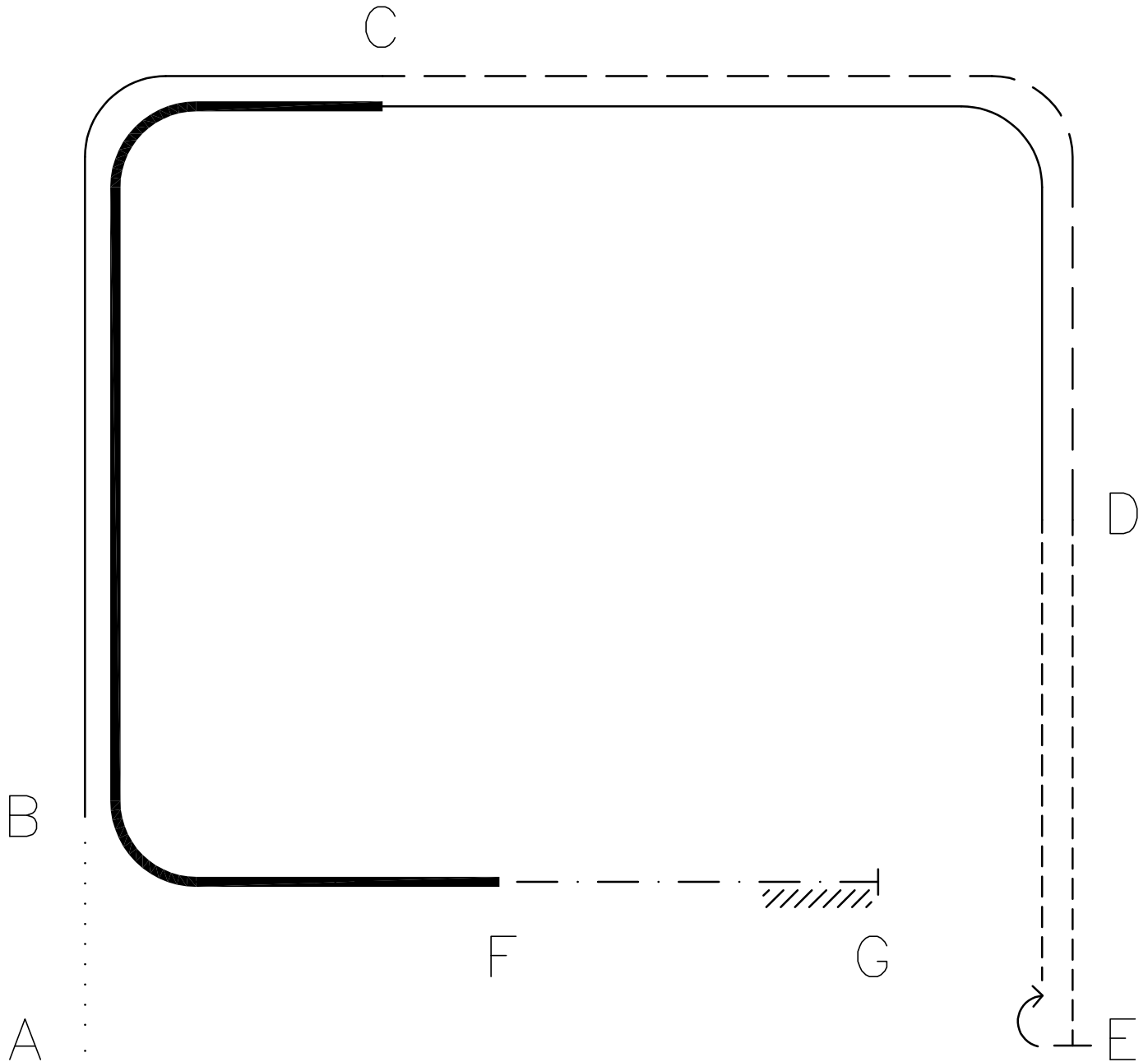

1. A to B - Walk
2. B to C - Lope
3. C to D - Extended Trot
4. D to E - Trot
5. Stop & Reverse
6. E to D - Trot
7. D to C - Lope
8. C to F - Extended Lope
9. F to G - Extended Walk
10. Stop and Back

GREELEY SADDLE CLUB

Ranch Riding - Green Horse and Youth 13 & Under

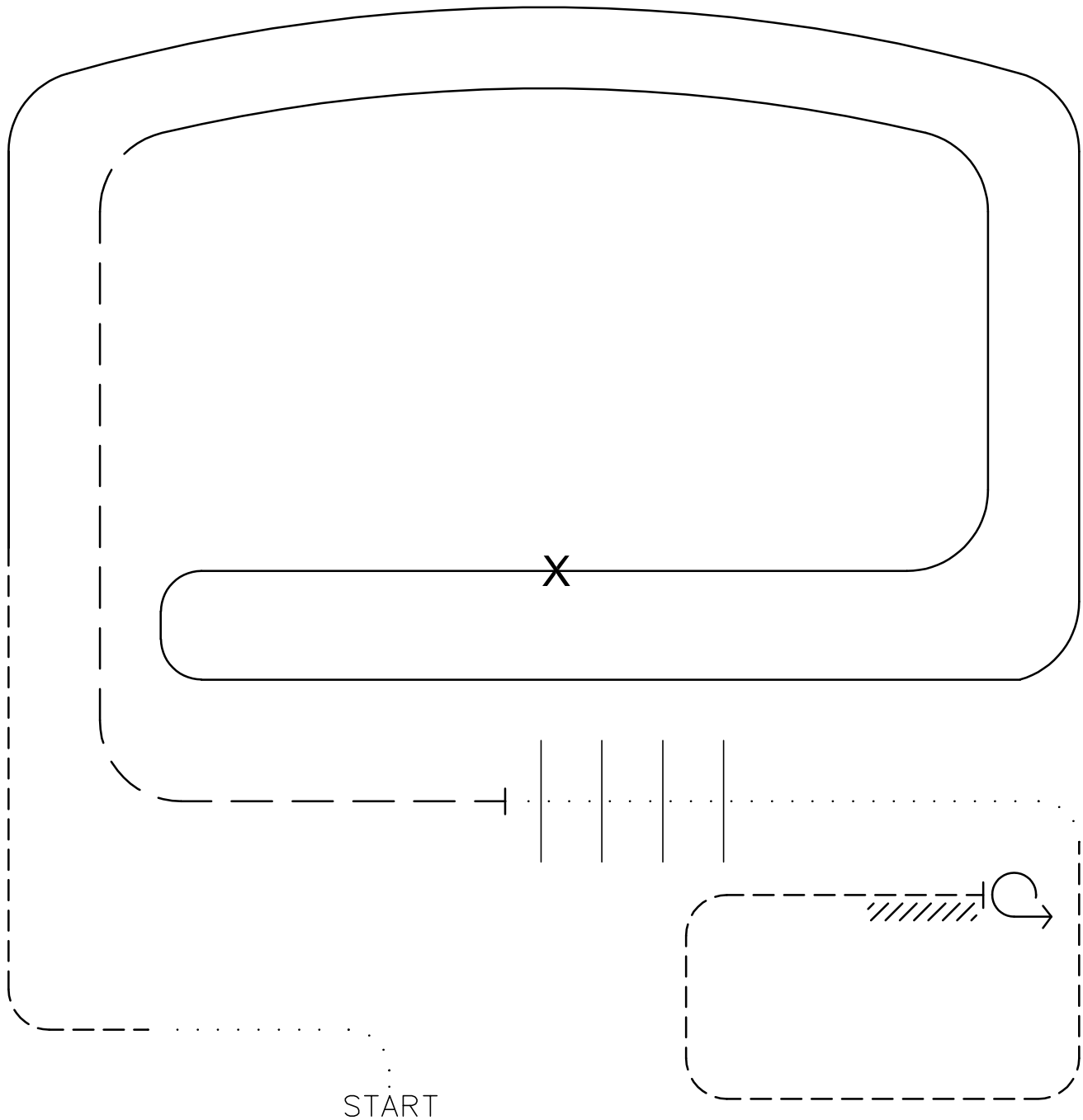

- | | |
|------------------------------------|---------------------------------|
| 1. Walk | 6. Extended trot |
| 2. Trot | 7. Stop and walk over logs |
| 3. Lope right lead | 8. Walk |
| 4. Change leads (simple or flying) | 9. Trot square |
| 5. Lope left lead | 10. Stop, 360° turn left & back |

GREELEY SADDLE CLUB

Ranch Riding - Youth 14-18, Amateur, Open

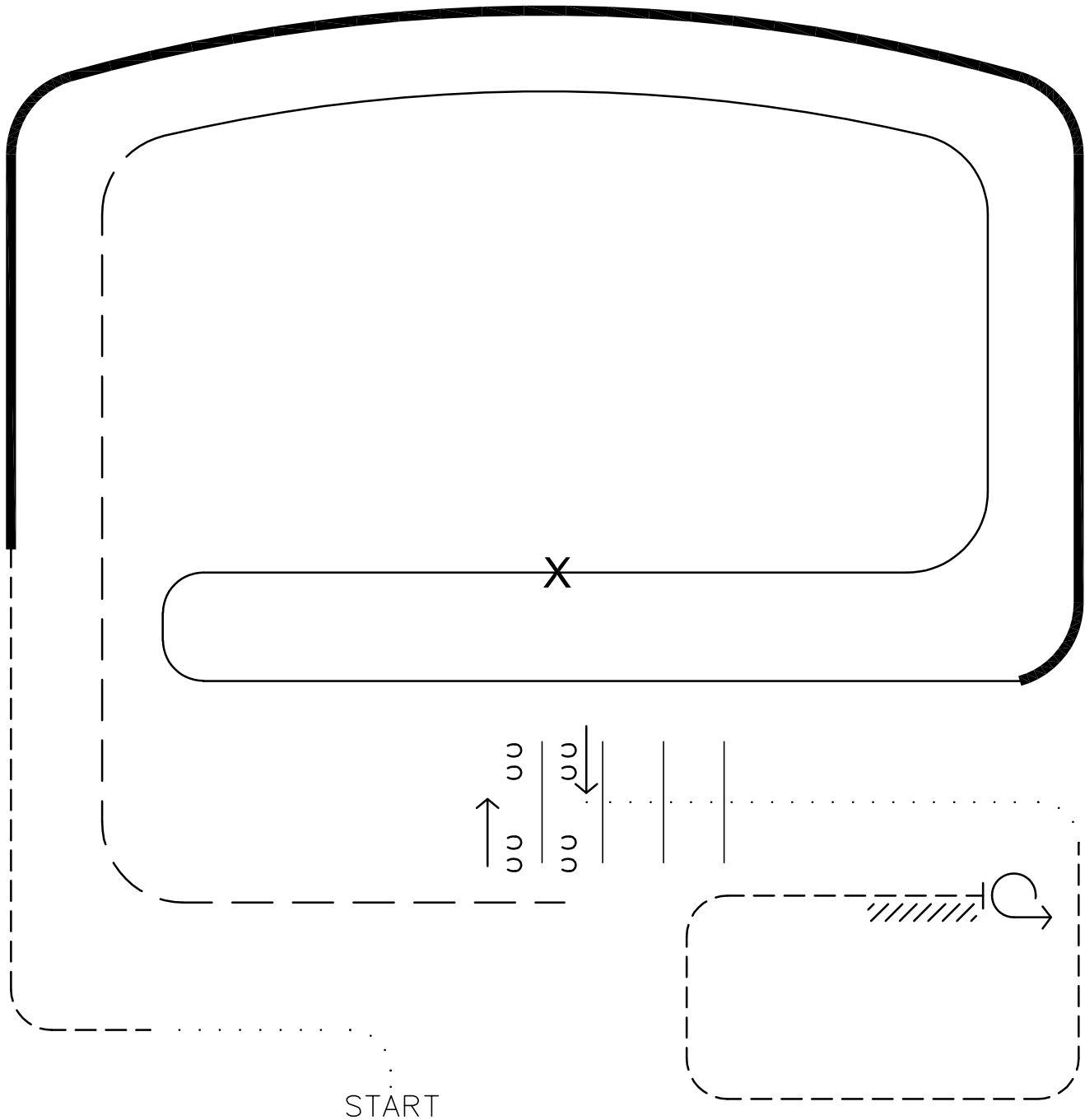

- | | |
|------------------------------------|--|
| 1. Walk | 7. Extended trot |
| 2. Trot | 8. Stop, side pass left, side pass right $\frac{1}{2}$ way |
| 3. Extended lope right lead | 9. Walk over logs |
| 4. Lope right lead | 10. Walk |
| 5. Change leads (simple or flying) | 11. Trot square |
| 6. Lope left lead | 12. Stop, 360° turn left & back |

GREELEY SADDLE CLUB

Ranch Reining - Green Horse and Youth 13 & Under

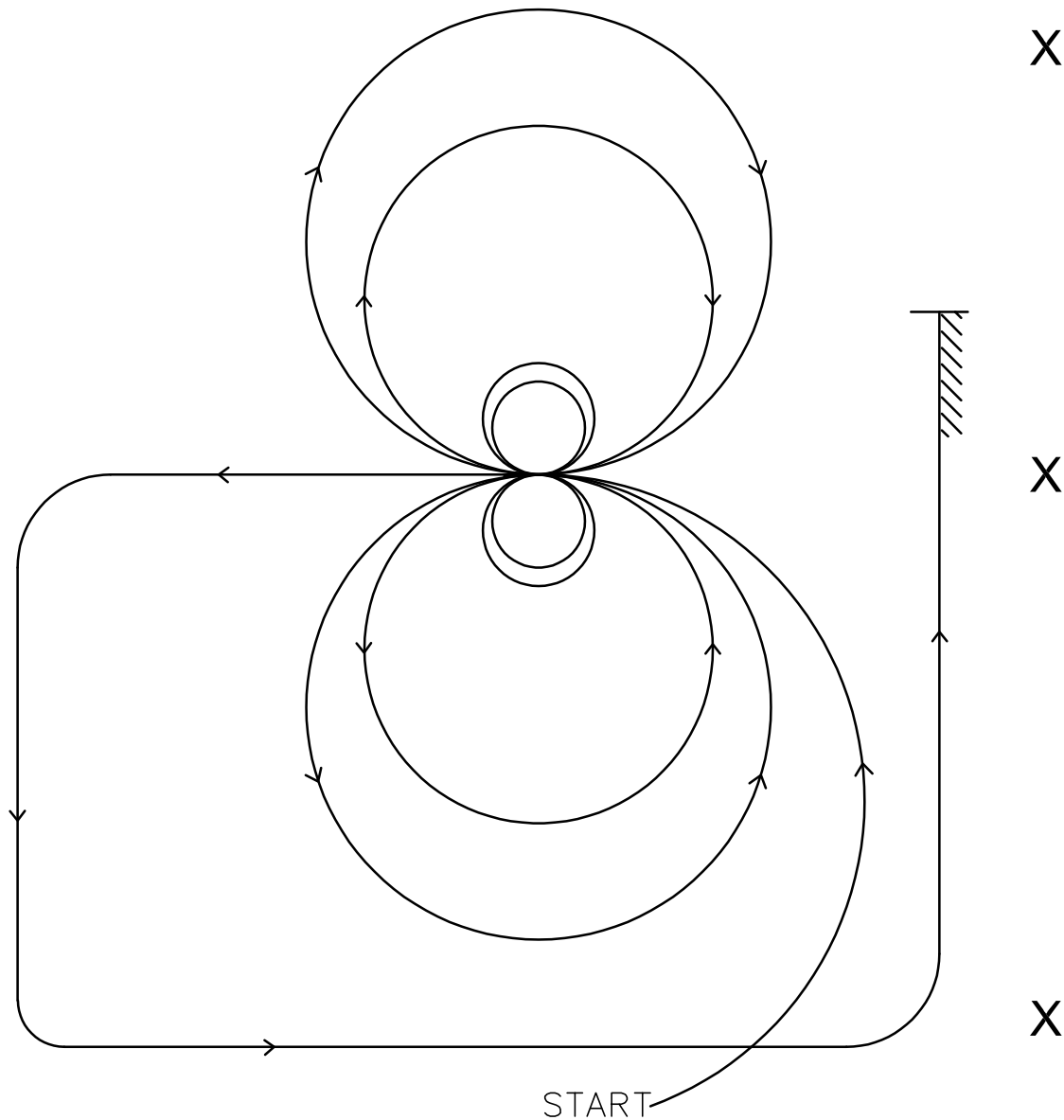

1. Begin on the left lead & lope to center. Without breaking complete two circles to the left, the first circle smaller and slower and the second circle larger and faster.
2. Stop back at the center. Complete 2 spins to the left.
3. Lope two circles to the right, the first circle smaller and slower and the second circle larger and faster.
4. Stop back at the center. Complete 2 spins to the right.
5. Lope on the left lead around the end of the arena without breaking or changing leads, run down the side of the arena past the end marker and execute a square sliding stop.
6. Back at least 10 feet in a straight line.

GREELEY SADDLE CLUB

Ranch Reining - Youth 14-18, Amateur, Open

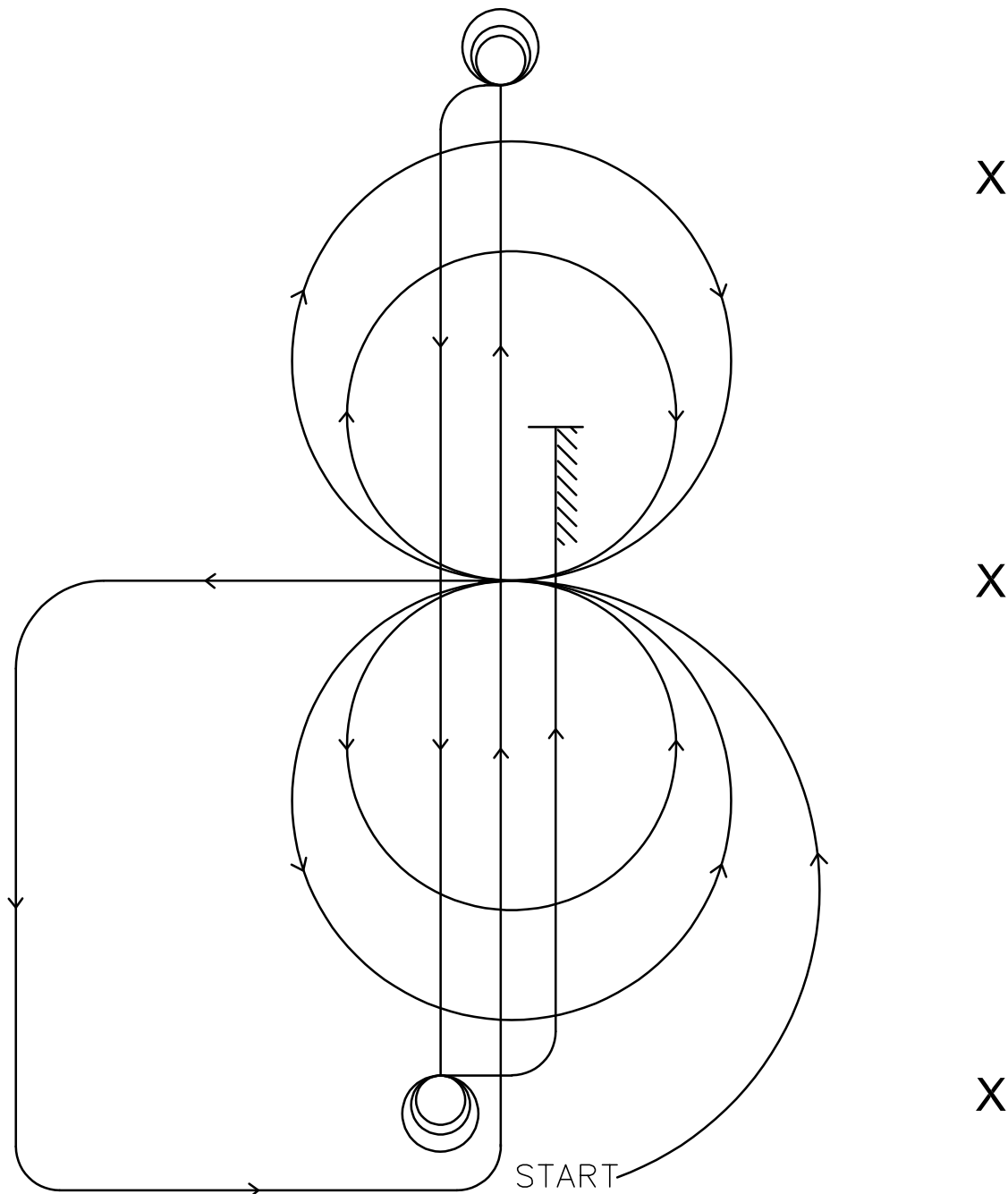

1. Begin on the left lead & lope to center. Without breaking complete two circles to the left, the first circle larger and faster than the second circle. Change leads.
2. Complete two circles to the right, the first circle larger and faster than the second circle. Change leads.
3. Continue around the end of the arena without breaking or changing leads, run down the center of the arena past the end marker and execute a square sliding stop.
4. Complete 3-1/2 spins to the left.
5. Run down to other end of the arena past the end marker and execute a square sliding stop.
6. Complete 3-1/2 spins to the right.
7. Run past the center marker and execute a square sliding stop.
8. Back at least 10 feet in a straight line.

GREELEY SADDLE CLUB

Ranch Trail - Green Horse and Youth 13 & Under

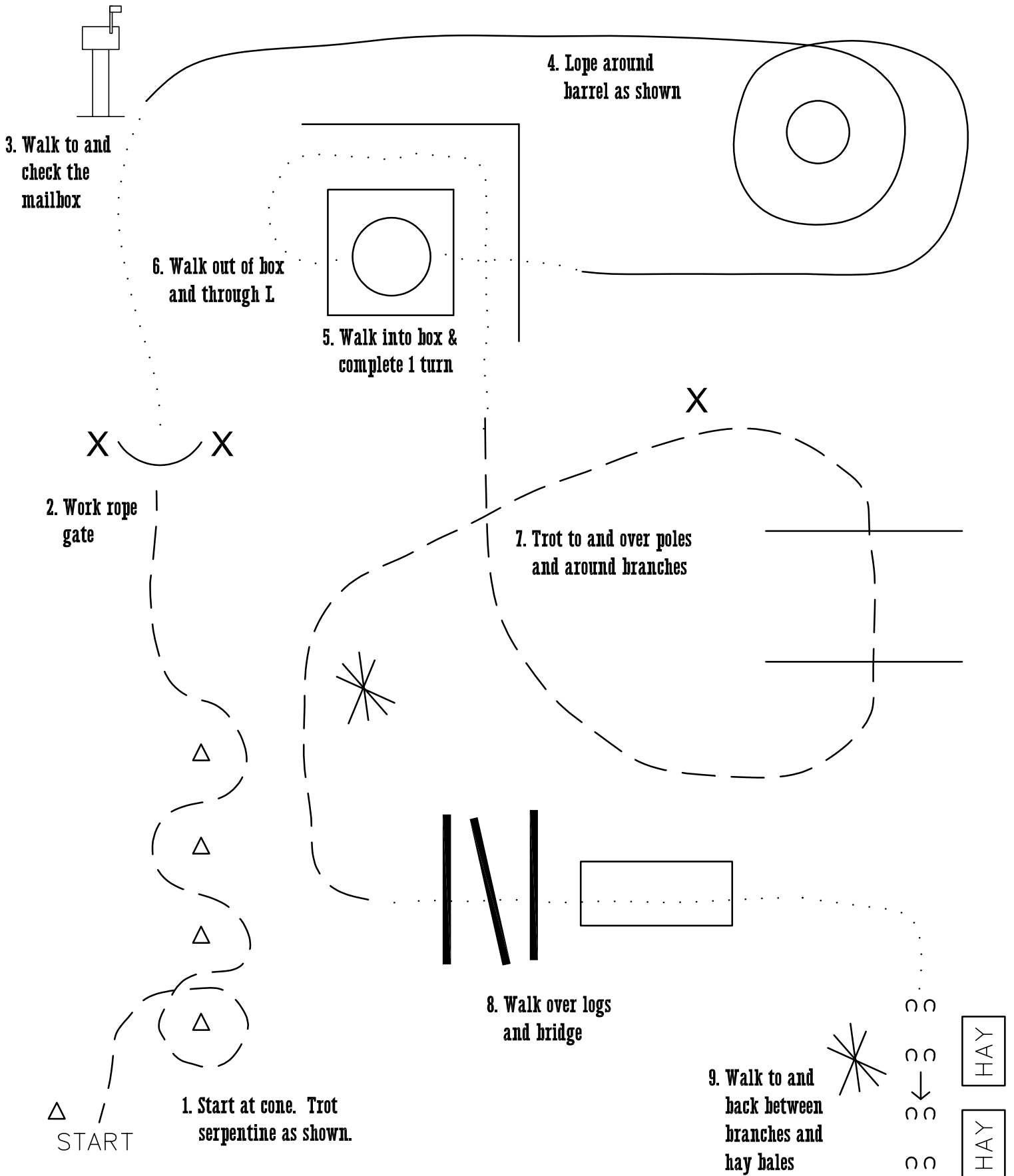

GREELEY SADDLE CLUB

Ranch Trail - Youth 14-18, Amateur, Open

