

# GREELEY SADDLE CLUB

Showmanship - Age Groups 5 & Under, 6-9, & 10-13

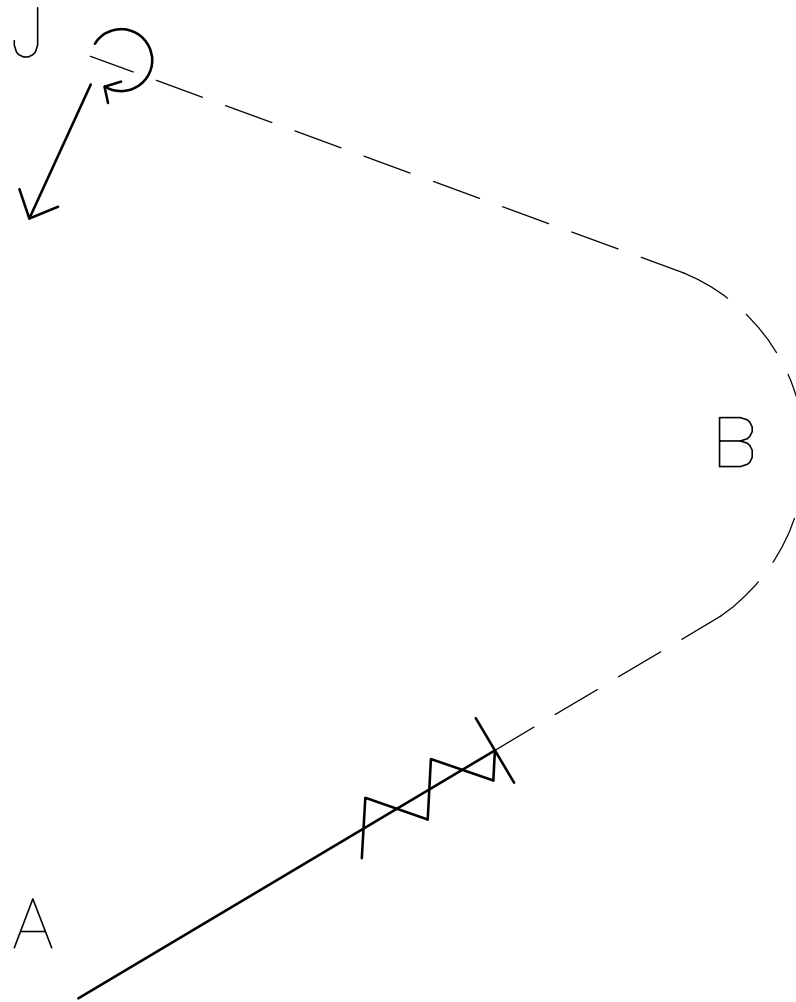

1. Start at A.
2. Walk halfway to B. Stop and back 5 steps.
3. Trot to and around B.
4. Continue on to the Judge. Set up for inspection.
5. When dismissed, complete a 270° turn and walk to line up.

# GREELEY SADDLE CLUB

Showmanship - Age Groups 14-18, 19-39, 40 & Over

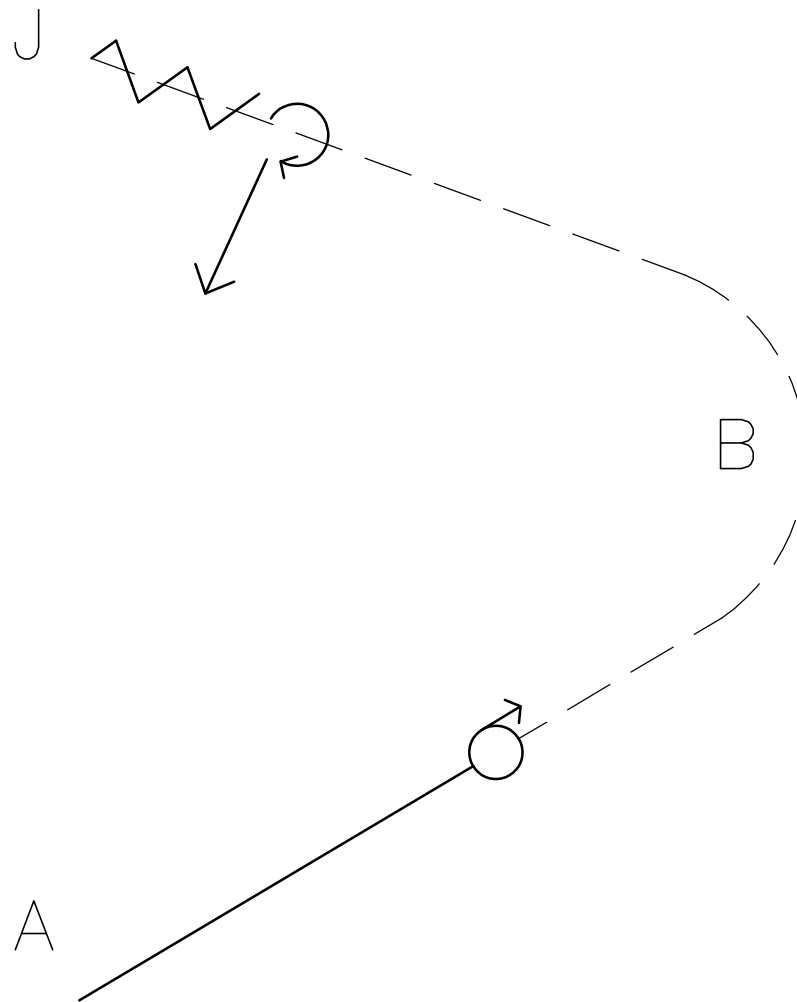

1. Start at A.
2. Walk halfway to B and stop. Execute a 360° turn.
3. Trot to and around B, continue on to the Judge.
4. Set up for inspection.
5. When dismissed, back 6 steps and then complete a 270° turn. Walk to line up.

# GREELEY SADDLE CLUB

## English Equitation - All Ages

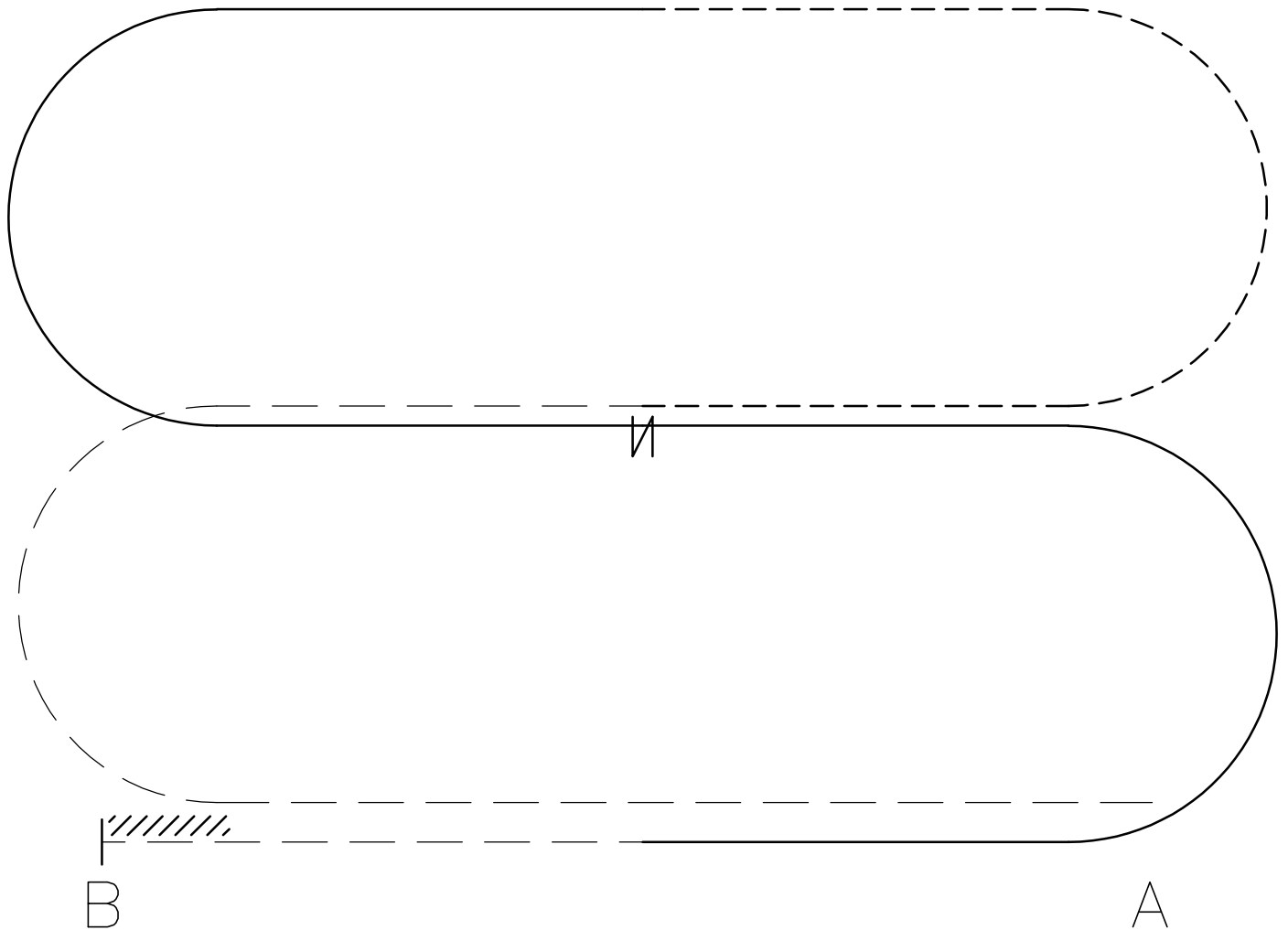

1. Start at A and trot on the left diagonal to B and around as shown.
2. Sitting trot midway between B and A to complete serpentine.
3. Pick up the left lead canter and continue around as shown.
4. Change leads back at the midway point and canter on the right lead to complete serpentine.
5. Posting trot on the right diagonal from the midway point back to B.
6. Stop at B. Back 2 horse lengths.

# GREELEY SADDLE CLUB

## Horsemanship - Age Groups 6-9 & 10-13

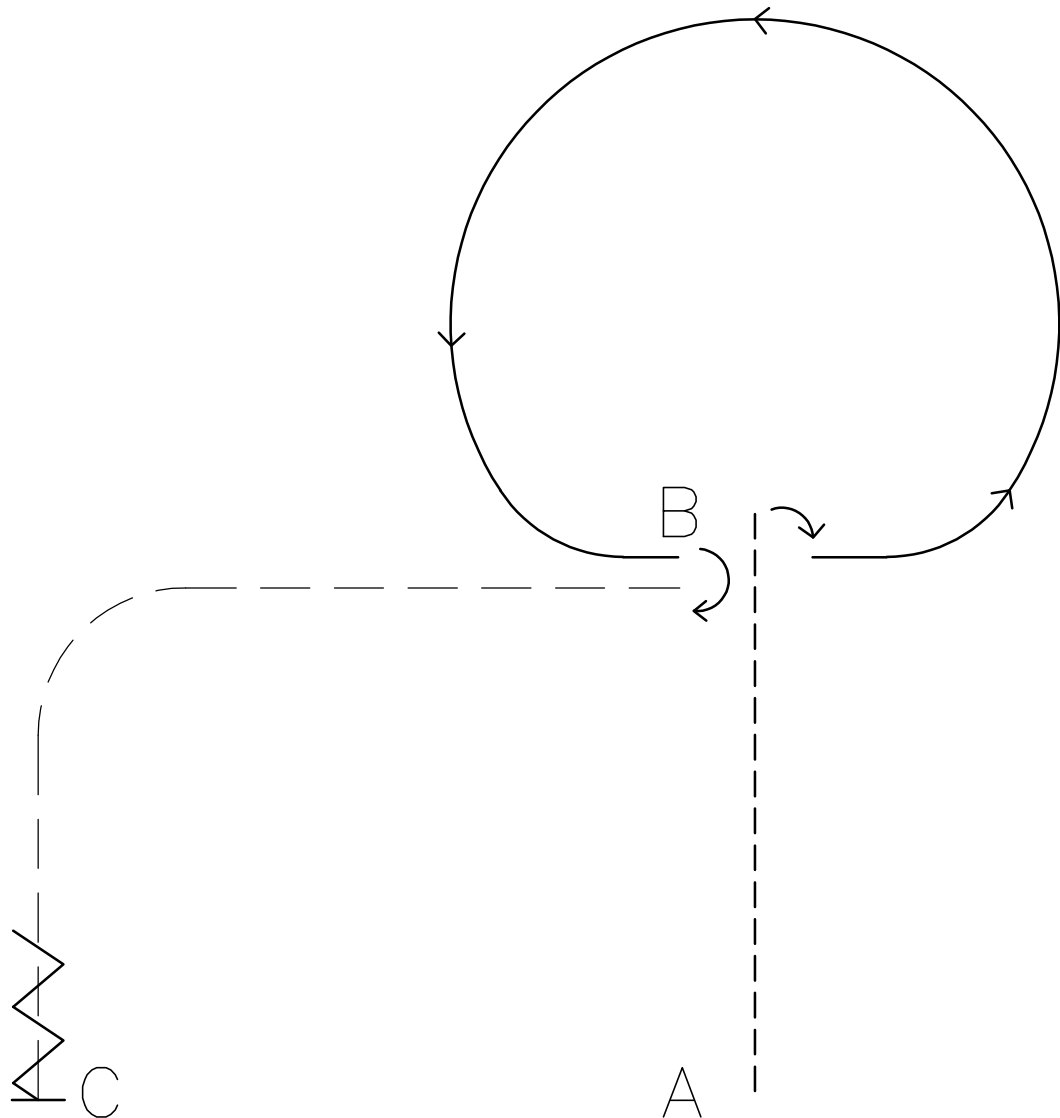

1. Start at A and jog to B.
2. Stop at B and perform a 90° turn to the right.
3. Lope a circle on the left lead around B.
4. Stop at B. Perform a 180° turn to the right.
5. Extended jog straight away from B and toward C as shown.
6. Stop at C. Back 5 steps.

# GREELEY SADDLE CLUB

Horsemanship - Age Groups 14-18, 19-39, 40 & Over

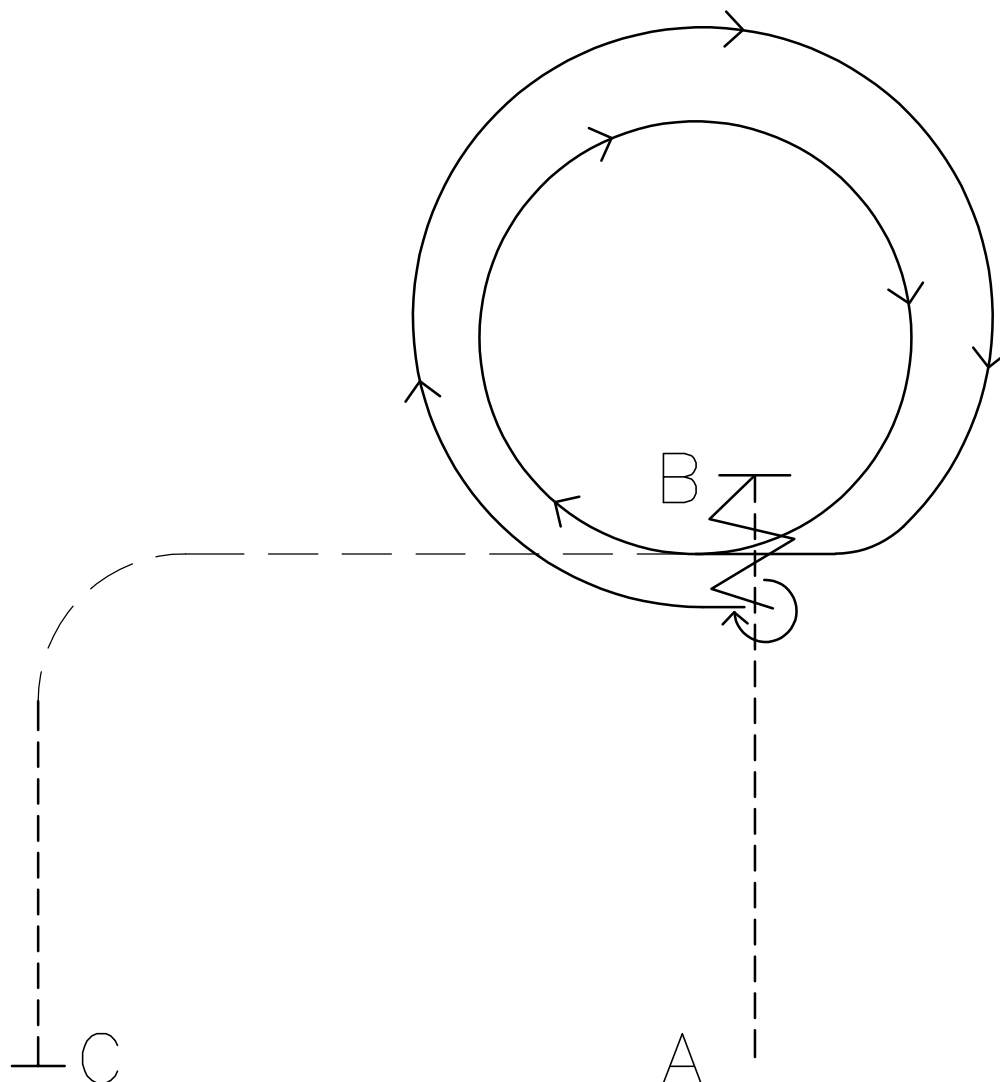

1. Start at A and jog to B.
2. Stop at B and back 5 steps. Perform a 270° turn to the right.
3. Complete a circle around B at an extended lope on the right lead.
4. Continue a second smaller circle around B at a collected lope.
5. At B, break down to an extended jog straight away from B.
6. Turn toward C as shown at a collected jog.
7. Stop at C.

# GREELEY SADDLE CLUB

## Reining - Age Group 6-9

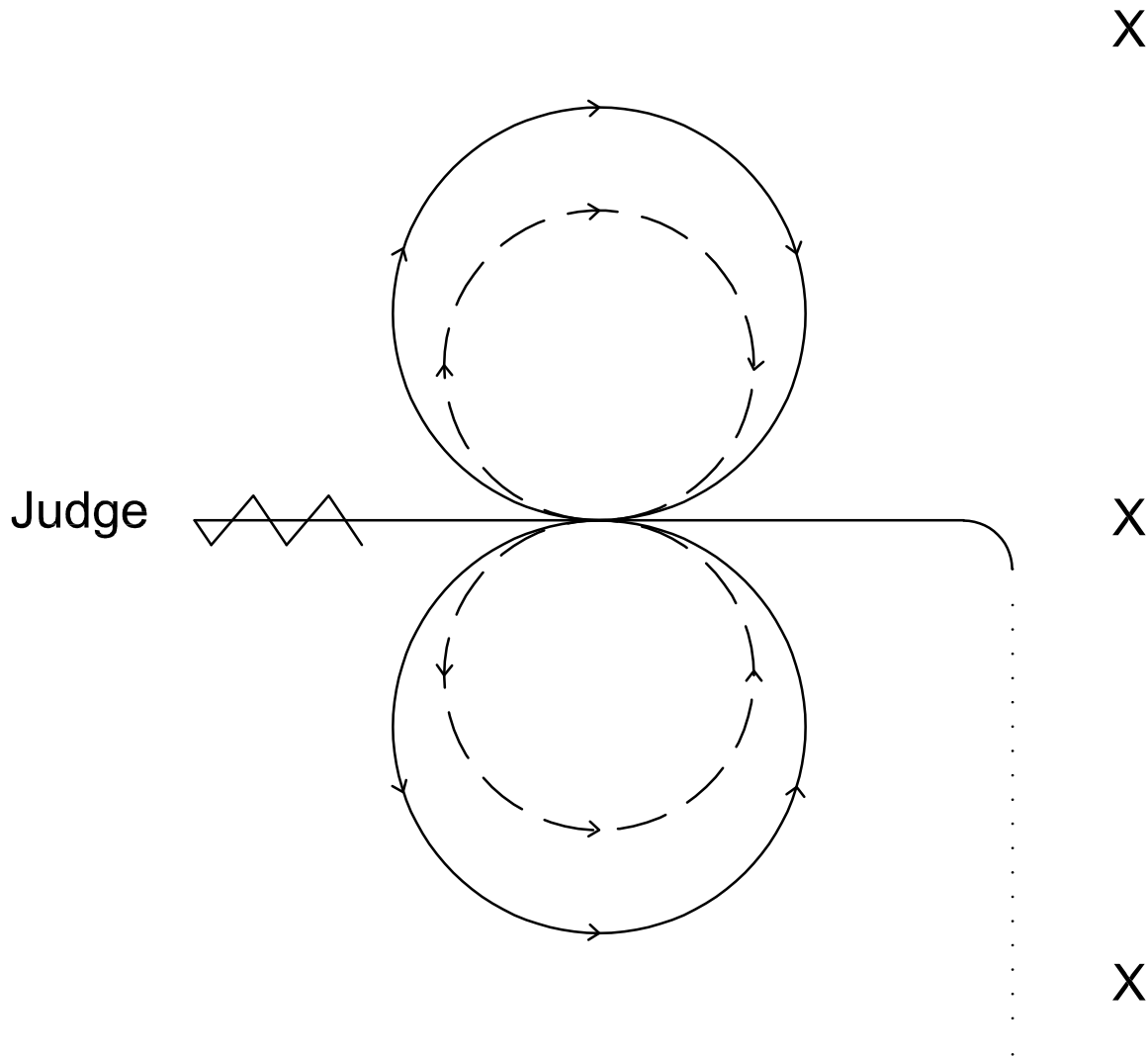

1. Walk to the center marker 20 feet from the fence.
2. Left lead to center.
3. Lope large figure 8 at moderate speed. Left circle first with a simple change at the center.
4. Jog a small figure 8 with a circle to the left first.
5. At the center, pick up the right lead. Lope straight for 10 feet.
6. Stop.
7. Back.
8. Walk to the judge for inspection.

# GREELEY SADDLE CLUB

Reining - Age Groups 10-13, 14-18, 19-39, 40 & Over

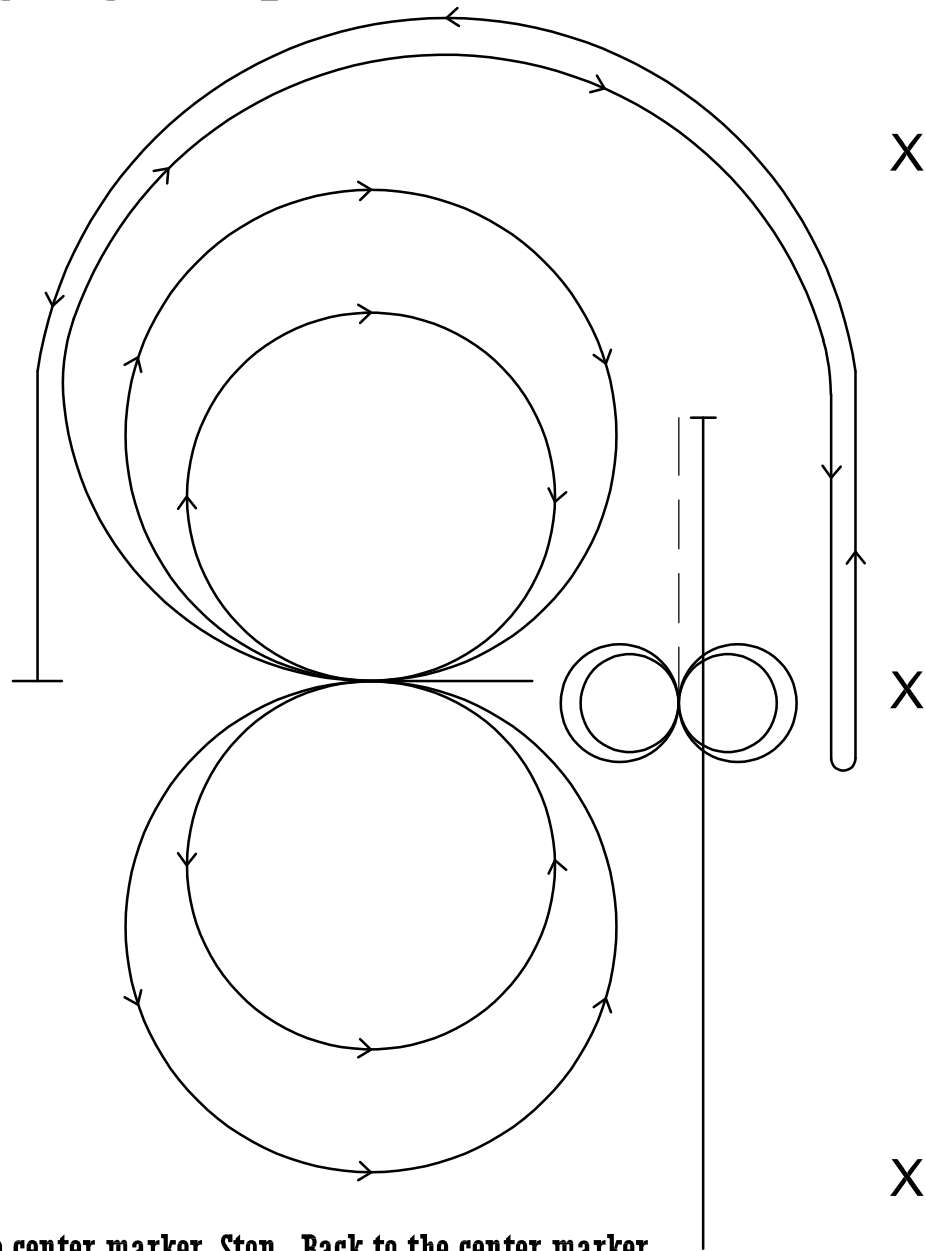

1. Run down past the center marker. Stop. Back to the center marker.
2. Complete two spins to the right.
3. Complete two and a quarter spins to the left.
4. Run two circles to the right with the first being smaller and slower and the second larger and faster.
5. Change leads at the center and complete two circles to the left the first smaller and slower and the second larger and faster.
6. Change leads at the center and start a circle to right, but do not close it. Run past the center marker and complete a rollback towards the fence.
7. Run back around the arena past the center marker and complete stop. Hesitate to show pattern completion.

# GREELEY SADDLE CLUB

## Trail - Age Groups 5 & Under, 6-9, & Novice

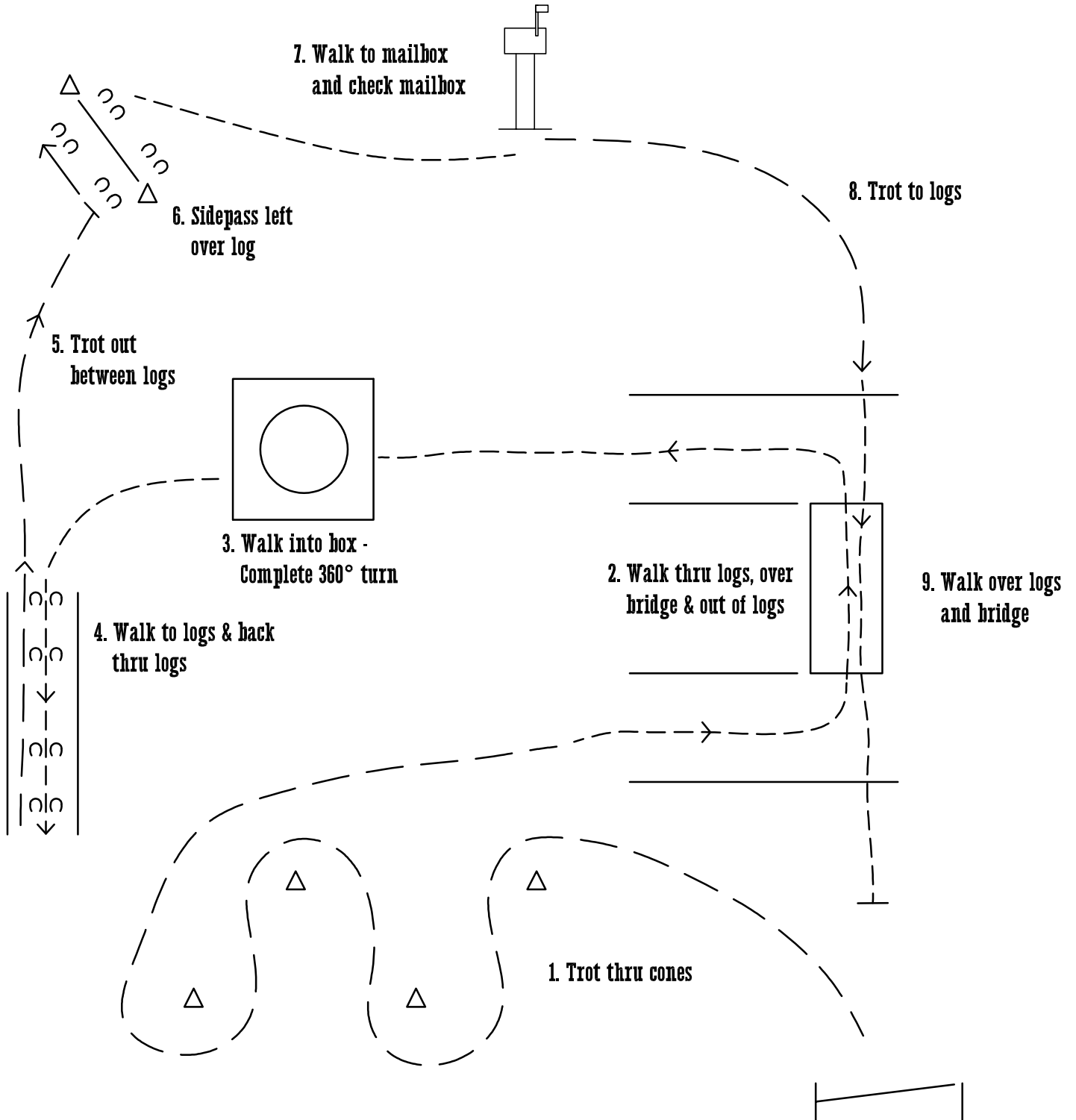



# GREELEY SADDLE CLUB

## Trail - Age Groups 10-13, 14-18, 19-39, 40 & Over

